

3

Arkiveres 2/5-1.

U-41

BA-85-5921-1.

25 APR 1985

**REGISTRERT
OLJEDIREKTORATET**

SOURCE ROCK POTENTIAL OF THE UPPER JURASSIC
SOURCE ROCKS IN THE 2/4-B19, 2/5-1 AND THE 2/4-11
WELLS, GROUP LICENSE AREA, NORWEGIAN SECTOR,
NORTH SEA

JOB NO. RE0210

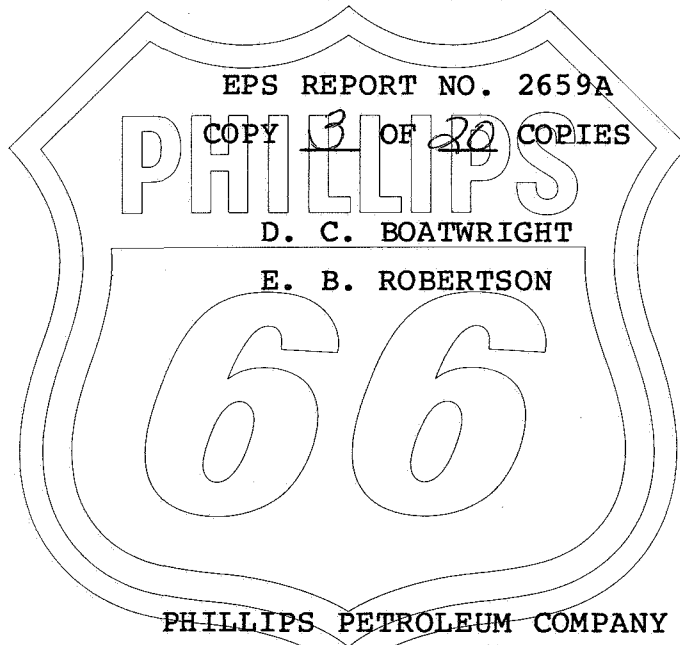

PHILLIPS PETROLEUM COMPANY
EXPLORATION PROJECTS SECTION
BARTLESVILLE, OKLAHOMA
APRIL, 1985

Source Rock Potential of the Upper Jurassic
 Source Rocks in the 2/4-B19, 2/5-1 and the 2/4-11 Wells,
 Group License Area, Norwegian Sector, North Sea
 EPS Report No. 2659A

Conclusions and Summary

The source rock potential of the Upper Jurassic sediments was determined for three wells in the Ekofisk/Tor Field areas. Each of the Upper Jurassic sections is at early to peak oil-phase maturity and should be actively generating and expelling hydrocarbons.

For the Upper Jurassic source rocks in the three wells, the remaining oil-generating potential and the pyolysis-based estimates of original (pre-catagenetic) potentials to generate extractable organic matter (EOM) are as follows:

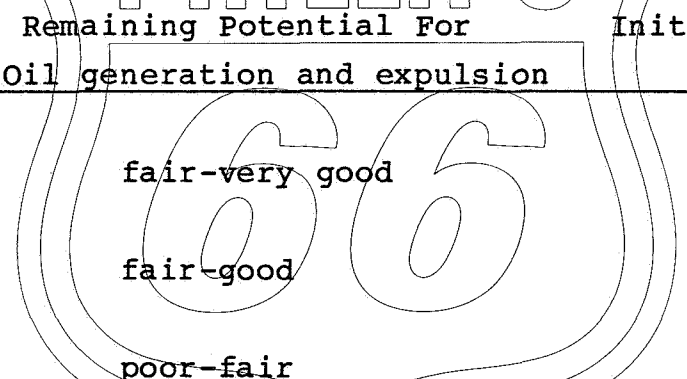

Well	Remaining Potential For Oil generation and expulsion	Initial Oil Potential (EOM, BAF)*
2/4-B19	fair-very good	16-88
2/5-1	fair-good	25-34
2/4-11	poor-fair	9-20

* Note: See Appendix A before using BAF data.

In all three wells there is a general decrease in the quality of the source rocks with depth (see Table I).

Discussion

A five-level descriptive scale is used to rank the source rock potential of rocks in this study. The scale, in decreasing

order of quality, is: Excellent; very good; good; fair; poor.

2/4-B19 Well

The Upper Jurassic sediments examined in this study (13,362-14,300 ft.) are thermally mature and have fair to very good remaining potential to generate and expel oil and gas. Vitrinite reflectance ($R_o = .65 - .88\%$) and thermal alteration indices (TAI = 3- to 3+) indicate that the interval has reached the main phase of oil generation maturity and should be actively generating and expelling petroleum.

The sample from 13,370-13,380' has the best source rock potential (very good: oil) of any portion of this Jurassic section and corresponds to a "hot" shale interval as indicated by gamma ray and sonic logs. It is rich in organic carbon (2.91%) and contains predominantly oil-prone kerogen (73%) which exhibits yellow and orange fluorescence under blue light. High hydrogen indices for the whole rock (302) and isolated kerogen (465) confirm the high oil generating potential of this interval.

Fair to good oil generating potential is indicated for the remaining Upper Jurassic sediments encountered in this well. The sediments have high TOC values (1.25-2.38%C) and abundant oil-prone kerogen (72-93%) which fluoresces under blue light. The shift in the fluorescence hue from orange to brown with depth is consistent with the observed increase in maturity. The moderate hydrogen indices (174-249 mgHC/gC) for the isolated kerogens may be the result of some combination of oxidation of the kerogen and previous generation and expulsion of hydrocarbons.

The original (pre-catagenetic) hydrocarbon generating potential for the Upper Jurassic sediments is estimated to have been fair to excellent, with hydrogen indices between 240 and 530 mgHC/gC and EOM yields of 16 to 88 BAF at peak oil-phase maturity.

2/5-1 Well

The Upper Jurassic interval, as represented by the samples in this study, contains high levels of organic carbon (TOC = 1.59-3.16%) and possesses fair to good remaining potential to generate oil and gas.

Visual examination of the isolated kerogens shows that the interval is near peak oil-phase maturity ($R_o = .77-0.84\%$); TAI = 3-to 3) and that the organic matter is dominated by oil-prone macerals (76-85%). Examination of the kerogens under blue light shows that orange and brown fluorescence is common for the pollen/spore populations and the amorphous macerals. The observed fluorescence is consistent with oil-prone kerogen near peak oil-phase maturity and suggests that the samples retain some oil generating potential.

Moderate hydrogen indices (HI = 159-251 mgHC/gC) for the isolated kerogens indicate that the remaining oil-generating potential of these samples is only fair to good. The moderate values may be the result of: (1) previous hydrocarbon generation and expulsion; (2) the partial oxidation of the organic matter prior to, during, or shortly after deposition; or, most likely, some combination of (1) and (2).

High production indices (PI = 0.59-0.7) and thermal extraction indices (TEI = 201-297 mgHC/gC) indicate that the interval contains abundant free bitumens which may represent non-indigenous, migrated petroleum or indigenous, unexpelled petroleum. Although the exact source of this bitumen cannot be determined by the present study, the fluorescence data are consistent with the interpretation that the bitumen is indigenous and the result of active generation and incomplete expulsion.

The original hydrocarbon generating potential for the Jurassic interval was good for oil and gas. The interval is estimated to have had kerogens with HI values ranging from 215-310

mgHc/gc and EOM yields from 25 to 34 BAF.

2/4-11 Well

The Jurassic sediments have reached the main phase of oil generation maturity with vitrinite reflectivities of 0.78 to 0.80%, and thermal alteration indices of 3- to 3.

The organic carbon content (TOC) ranges from .63% (fair) to 1.82% (good) and all the rocks are considered to have some remaining potential for generating petroleum (gas or oil). The general predominance of liquid-prone kerogen macerals (65-87%) suggests a marine dominated depositional environment with low to moderate terrestrial input. The relatively low hydrogen indices (82-105, whole rock; and 159-255, isolated kerogen) indicate that the organic matter may have been oxidized prior to, during or shortly after deposition. Oxidation would not only reduce the quantity of hydrocarbons generated, but would shift the type of hydrocarbons from liquid toward gas.

The original hydrocarbon generating potential for the Upper Jurassic sediments is estimated to have been poor to fair with hydrogen indices between 220 and 305 mgHC/gC and EOM yields of 9 to 20 BAF at peak oil-phase maturity.

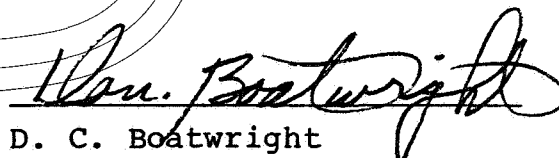

D. C. Boatwright
Geochemist

Approved: M. E. Smith / MUM

M. E. Smith
Geochemistry Supervisor

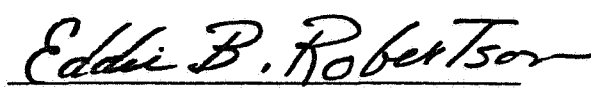

E. B. Robertson
Palynologist

Approved: E. A. Stanley

E. A. Stanley
Biostratigraphic Supervisor

Appendix A

The presentation of numerical estimates of the barrels per acre-foot (BAF) of the amount of EOM that the source rock could generate at peak oil generation maturity is a new addition to our basic source rock analysis reports. These peak BAF values are not precise, because they are based on certain assumptions and estimations that may not be precise; therefore, they should be used with restraint and caution. We feel that their most appropriate use is in comparing one source rock to another, but they can be used to make "ball-park" estimates of the amounts of EOM that could have been generated in a given area if the source rock can be assumed to have reached or exceeded peak oil generation maturity. It must be emphasized that these peak BAF figures represent only estimated potential generation of solvent-extractable organic matter (EOM), and do not take into account expulsion efficiency, migration efficiency or trapping efficiency. All of these factors must be considered when trying to determine if a given body of source rock could have generated sufficient hydrocarbons to fill a given trap (or traps).

The peak BAF figure is a quantitative expression of source rock quality, not kerogen quality, because a high TOC can compensate for lower kerogen quality in the estimation of peak BAF.

If peak BAF and source rock maturity are promising, an evaluation by QEST modeling of petroleum generation is recommended. QEST will estimate the timing of generation and also BAF as a function of maturity. At low to moderate heating rates (burial rates) the peak BAF from QEST using hydrogen index input can be from slightly to rarely over 10% higher. At very rapid heating rates, the QEST peak BAF may be somewhat lower. If QEST is run with visual kerogen type instead of HI, the peak BAF may be from slightly to much higher.

A summary of the procedures used to generate the peak BAF data follows:

1. The procedure is limited to samples which show no evidence of the presence of organic contamination or of migrating or reservoired oil or bitumen.
2. The procedure is not applicable to samples with less than 0.5% TOC and is more reliable when applied to samples with over 1% TOC.
3. The procedure requires the following data:
 - a. Kerogen maturity on the vitrinite reflectance (Ro) scale.
 - b. The hydrogen index (HI) of isolated kerogen (not the whole-rock hydrogen index normally measured by "Rock Eval").
 - c. The total organic carbon content (% TOC).
4. If the maturity level of the kerogen in the sample is 0.5 or less on the Ro scale, the procedure is as follows. If not, go to step 3.

Step 1 From the hydrogen index of the isolated kerogen, a non-linear relationship based on QEST modeling is used to estimate the barrels of EOM at peak oil generation per acre foot per percent TOC.

Step 2 The figure from step 1 is multiplied by %TOC to obtain barrels of EOM per acre foot. If inertinite is greater than about 5%, multiply by (1-weight fraction inertinite).

5. If the maturity level of the kerogen is greater than 0.5 on the Ro scale, the HI and TOC which existed when the sample was immature are estimated from the measured data at the

higher maturity; and then steps 1 and 2 are followed as with an immature sample.

Step 3 The measured hydrogen index and maturity are used with a nomograph based on QEST modeling of petroleum generation to estimate the hydrogen index which existed when the sample was immature.

Step 4 The measured TOC and maturity are used with a nomograph based on QEST modeling of petroleum generation to estimate the TOC which existed when the sample was immature.

Step 5 The results of steps 3 and 4 are used for steps 1 and 2.

6. From visual kerogen type, a maximum value for peak BAF can be estimated. If the visual appearance and fluorescence of the kerogen indicate a lack of oxidation of the kerogen, i.e., excellent organic matter preservation conditions, then the max peak BAF from visual should be close to that estimated from the hydrogen index, steps 1-5 above. Otherwise, the max peak BAF will be larger, possibly much larger.

Step 6 The maximum peak BAF per 1% TOC from visual kerogen type is estimated as follows:

$$\text{Max peak BAF per 1\% initial TOC} = (\% \text{ oil-prone}) \times 37.3 + (1 - \% \text{ oil-prone}) \times 14.1$$

(If inertinite is greater than about 5%, the visual kerogen type is first normalized to an inertinite-free basis.)

Step 7 If the maturity of the sample is greater than

0.5 on the Ro scale, determine initial TOC as in step 4.

Step 8 The max peak BAF from step 6 is multiplied by the initial %TOC from step 7. If inertinite abundance is greater than about 5%, multiply by (1-weight fraction inertinite).

7. The optimism of the max peak BAF from visual kerogen type is warranted only if there is good reason to believe that the major source rock unit was deposited under excellent organic preservation conditions.

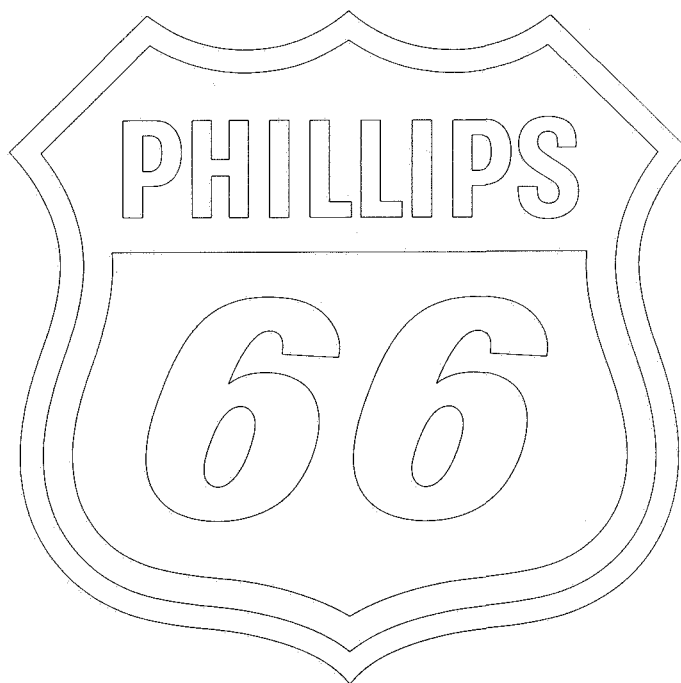

— CORE
 // CUTTINGS

BIOSTRAT
 COMPOSITE

PLIOCENE

MIO-OLIG

EO-PALEO

CRET

TOTAL ORGANIC CARBON

wt% of rock

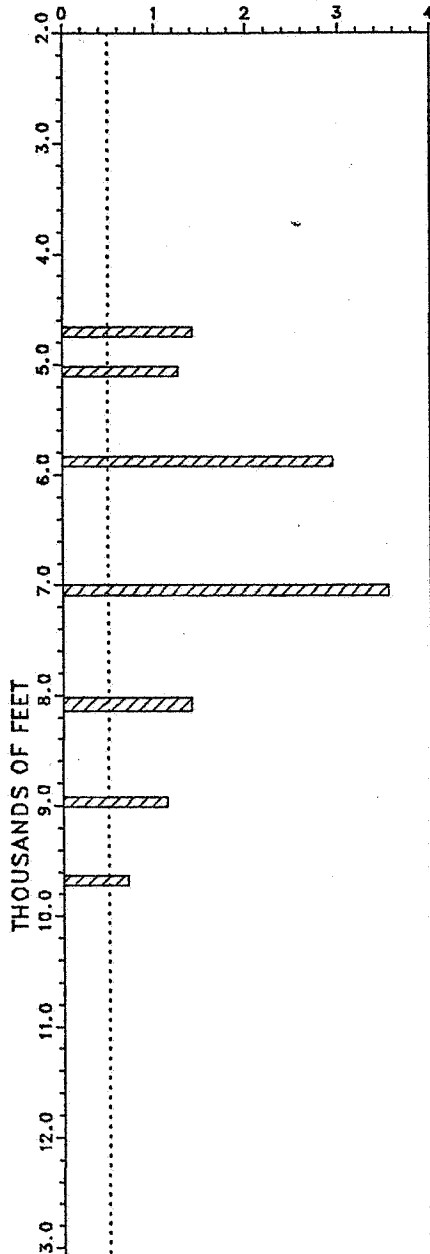

S1 PEAK

TEH

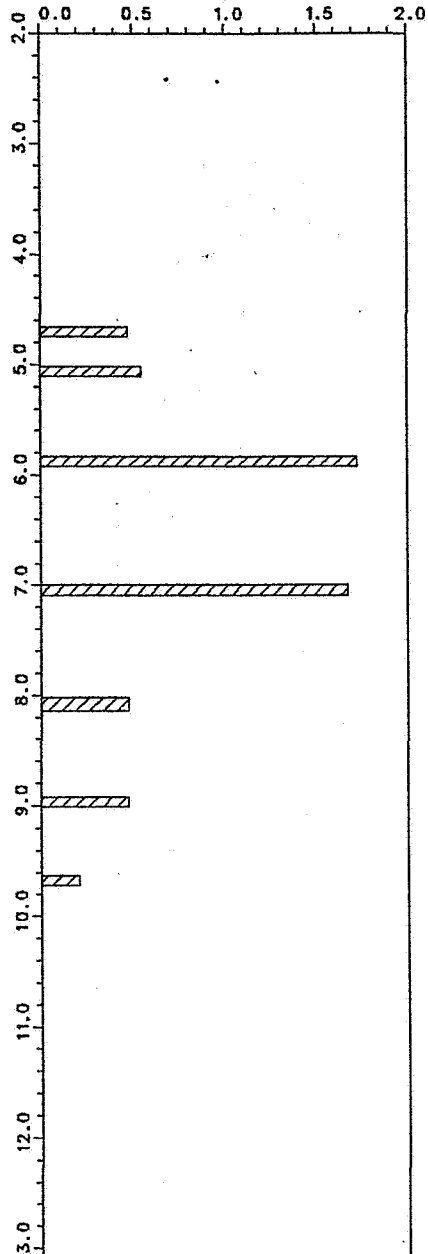

S2 PEAK

mg per gram of rock

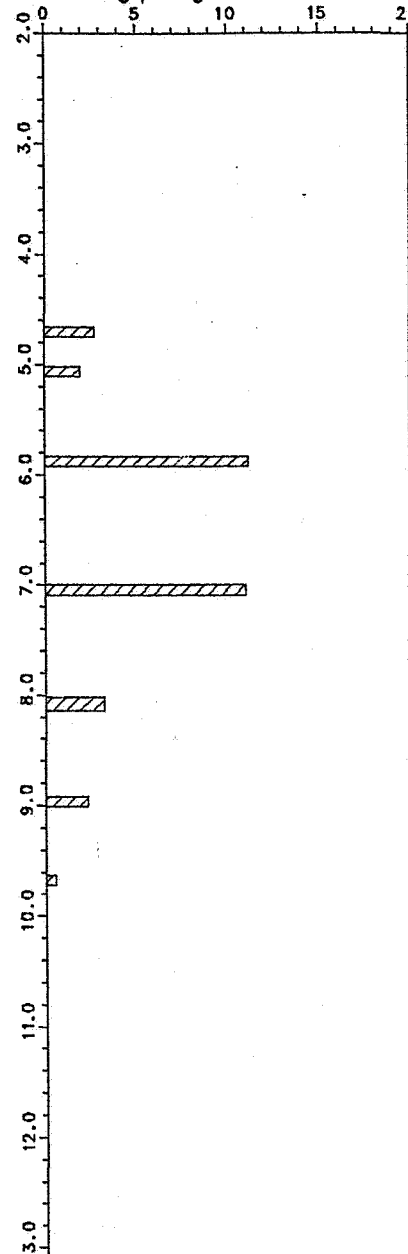

PRODUCTION INDEX

generation ratio

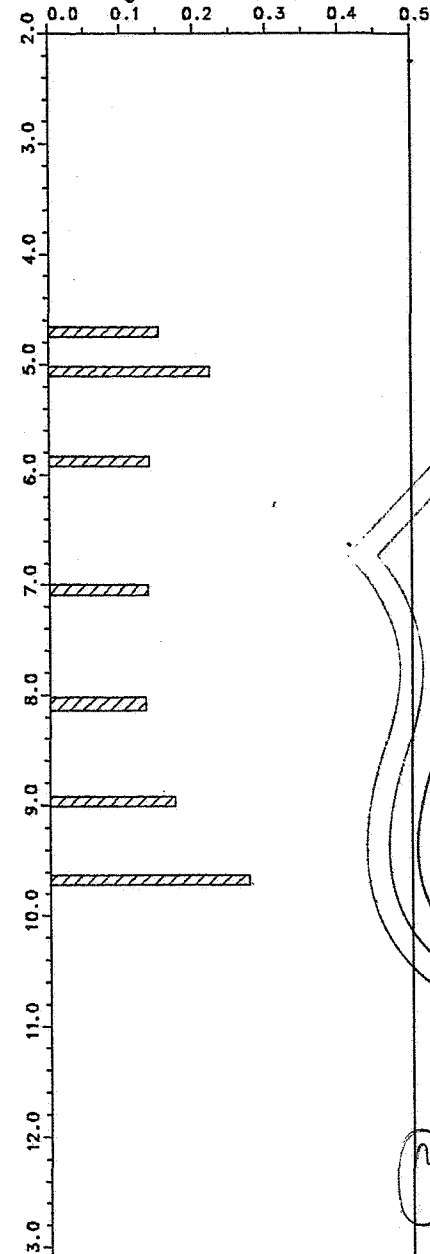

THERMAL EXTRACTION

mg per gram of rock

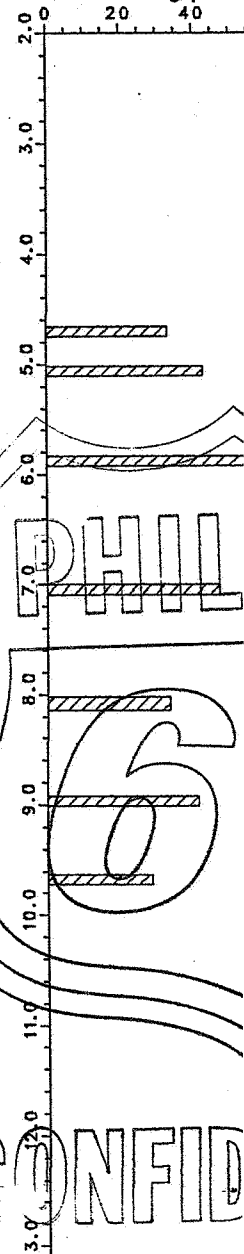

PHIL
 6
 CONFID

NORWEGIAN SECTOR, NORTH SEA (WHOLE ROCK)

ROCK GEOCHEMICAL AND VISUAL KEROGEN DATA

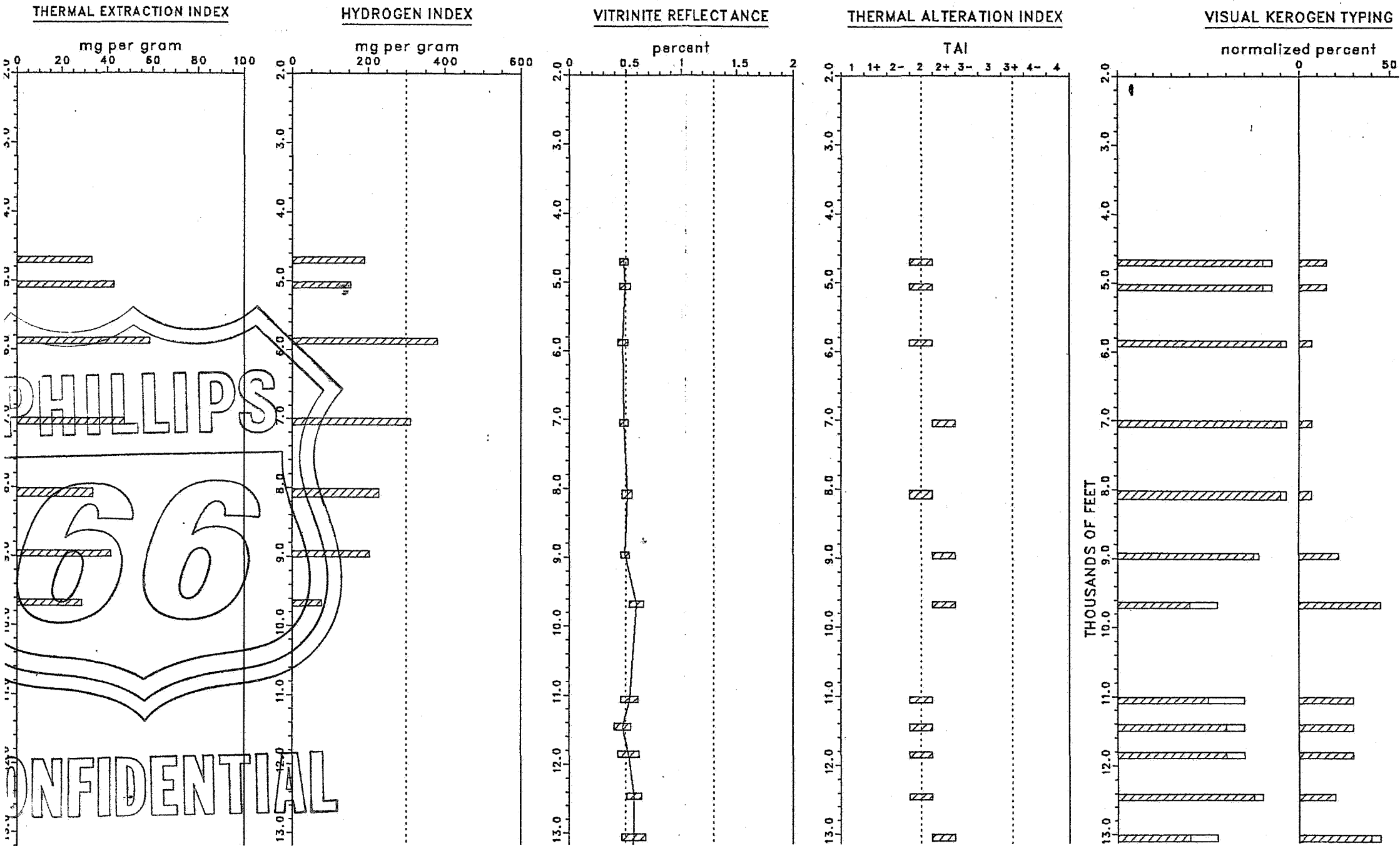

— CORE
 // CUTTINGS

EKOFISK 2/4-B19, NORWEGIAN SECTOR, N. SEA (ISOLATED KEROGENE)

PYROLYSIS RESULTS

BIOSTRAT
 COMPOSITE

PLIOCENE

MIO-OLIG

EO-PALEO

CRET

TOTAL ORGANIC CARBON

wt% of rock

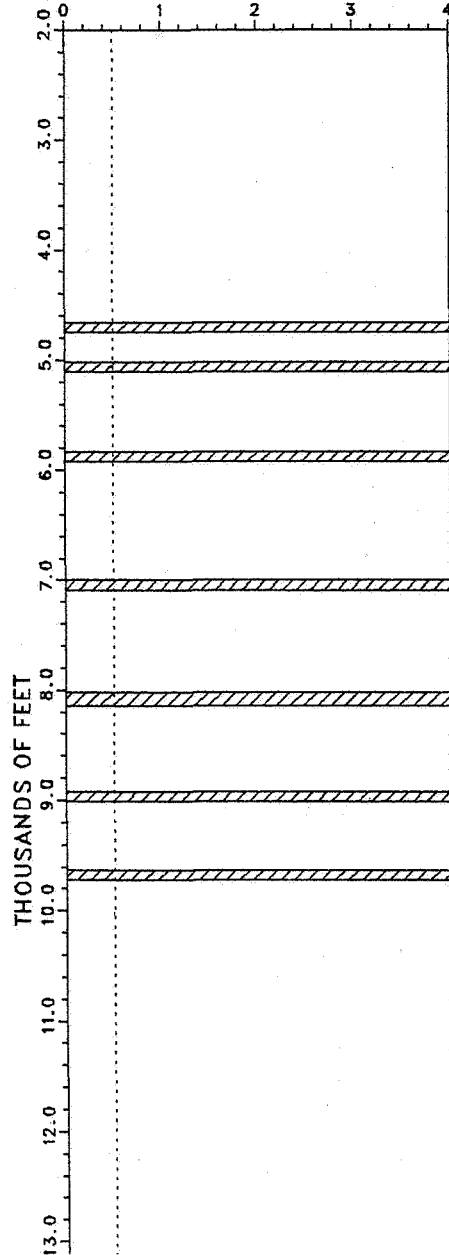

S1 PEAK

TEH

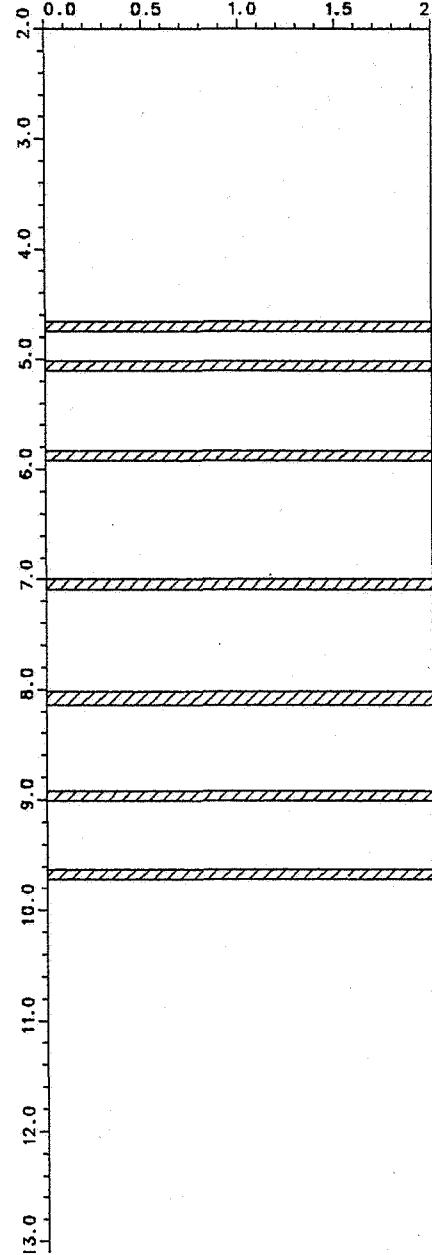

S2 PEAK

mg per gram of rock

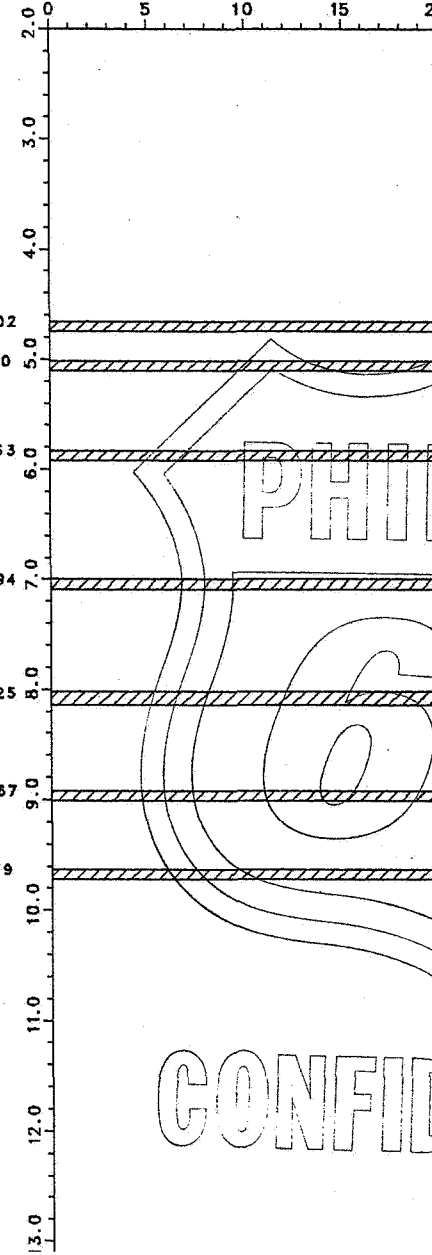

PRODUCTION INDEX

generation ratio

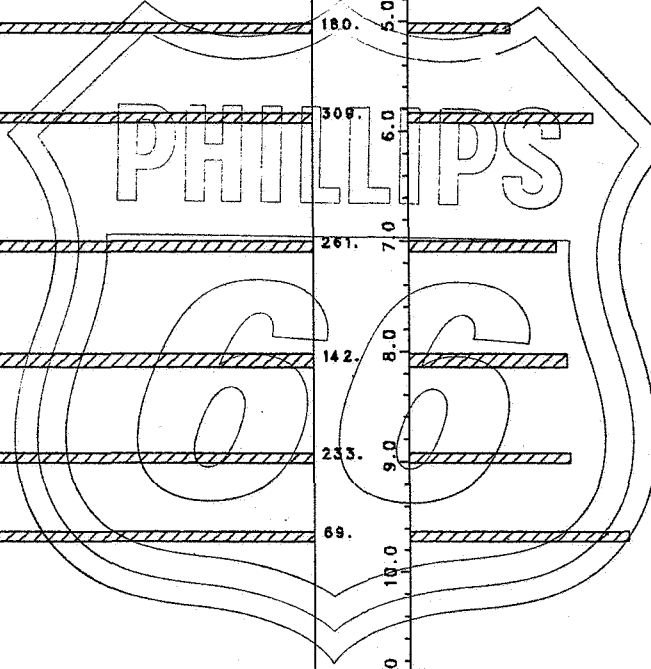
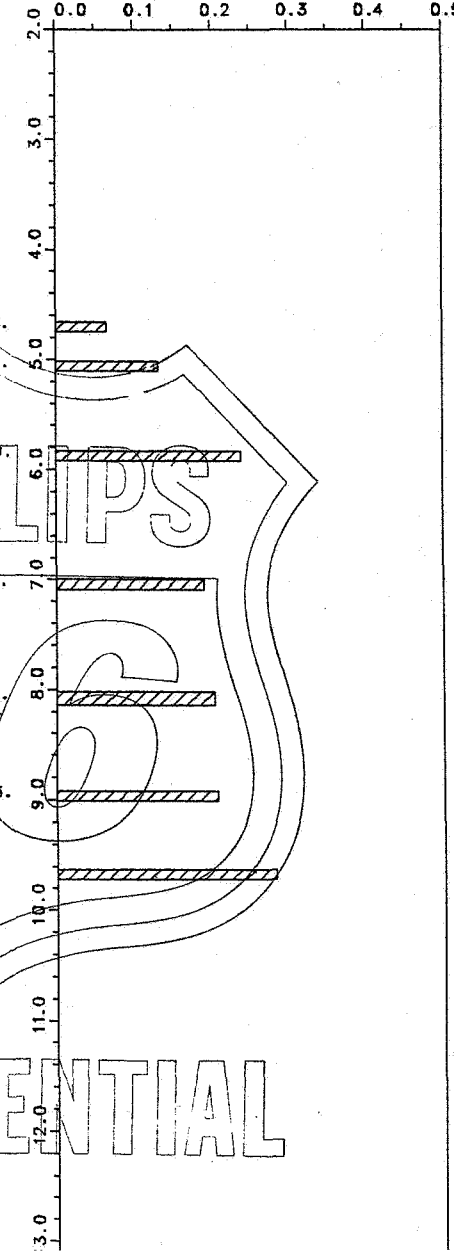

CONFIDENTIAL

EKOFISK 2/4-B19, NORWEGIAN SECTOR, N. SEA (ISOLATED KEROGEN)

PYROLYSIS RESULTS

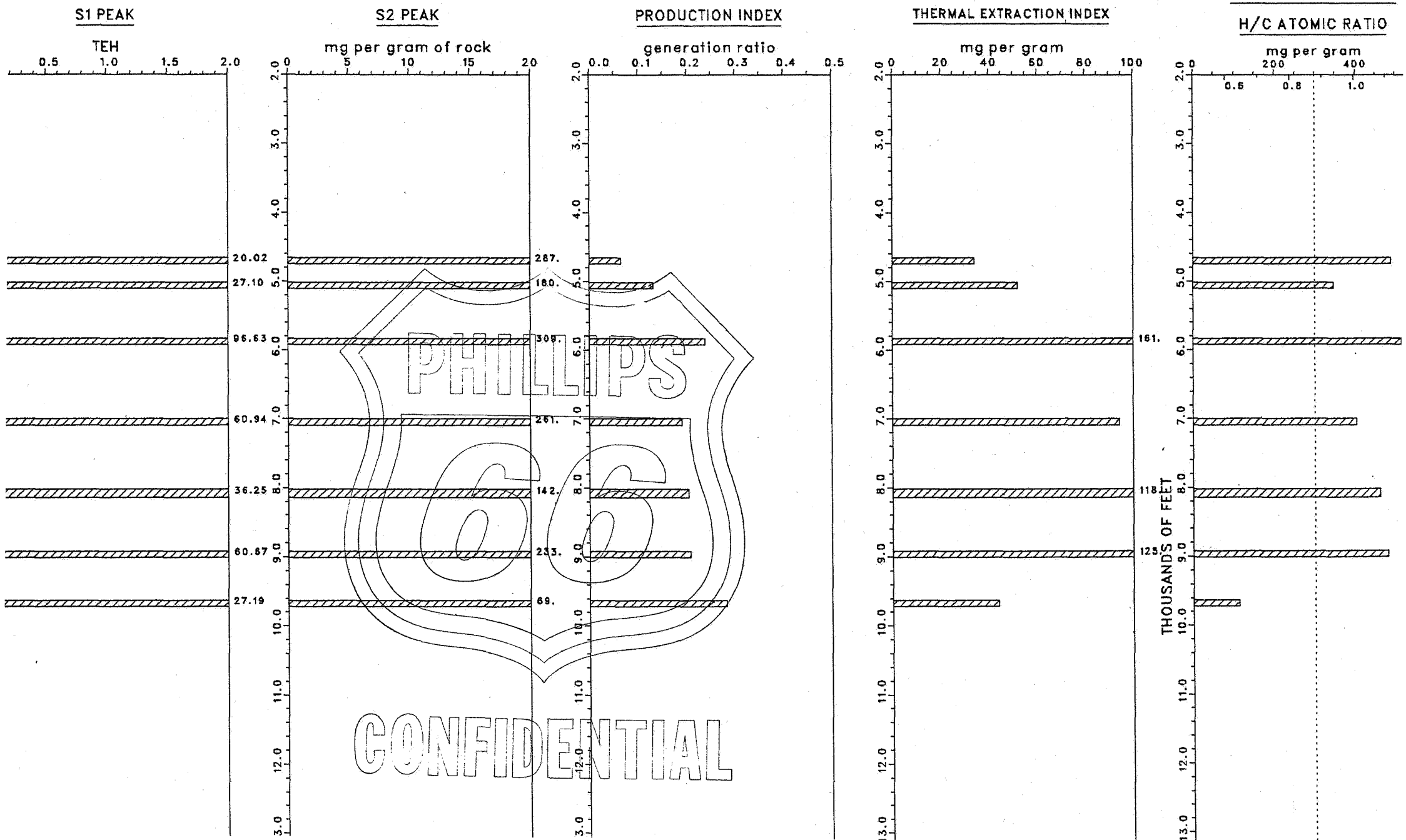

— CORE
 ▨ CUTTINGS

BIOSTRAT
 COMPOSITE

PLIOCENE

MIO-OLIG

EO-PALEO

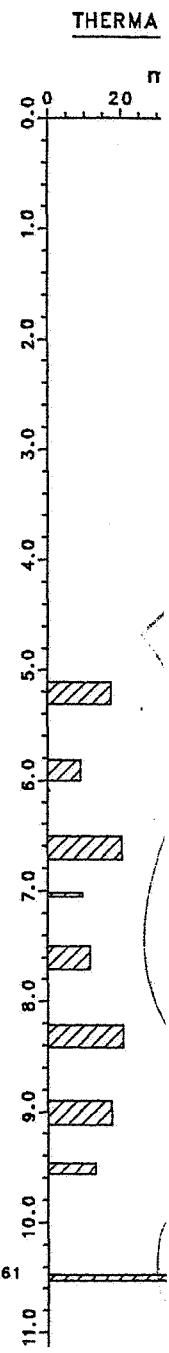
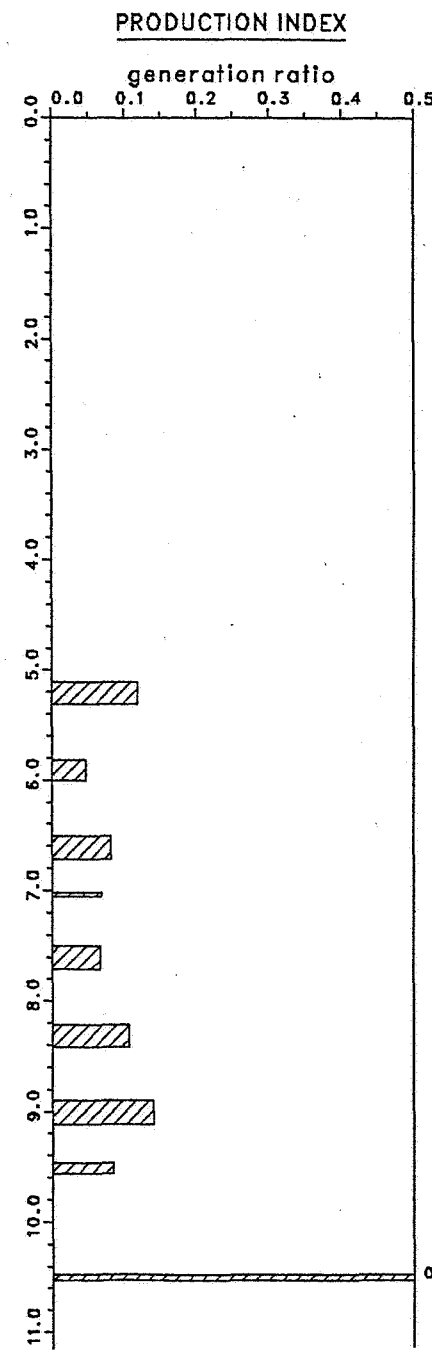
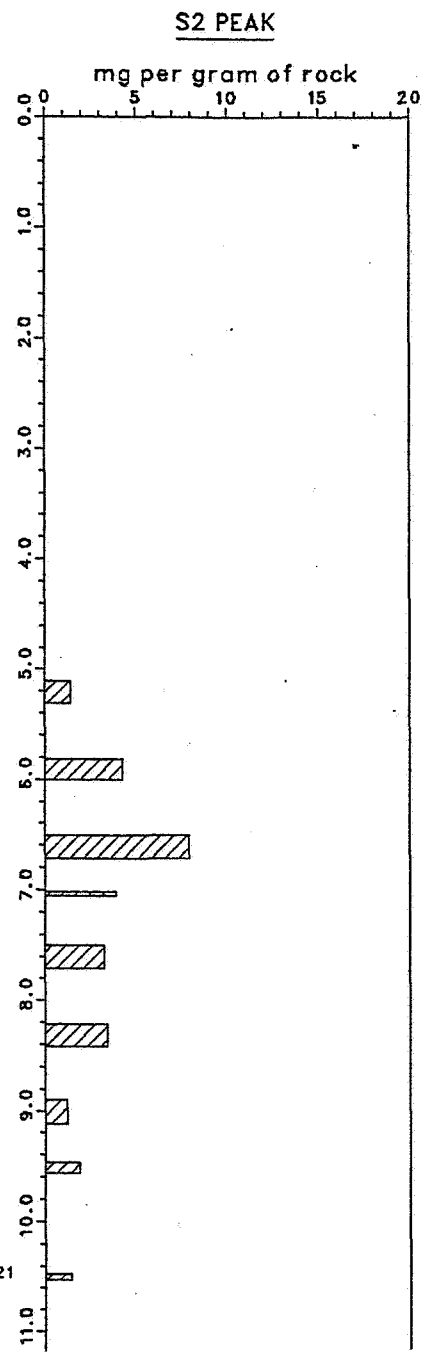
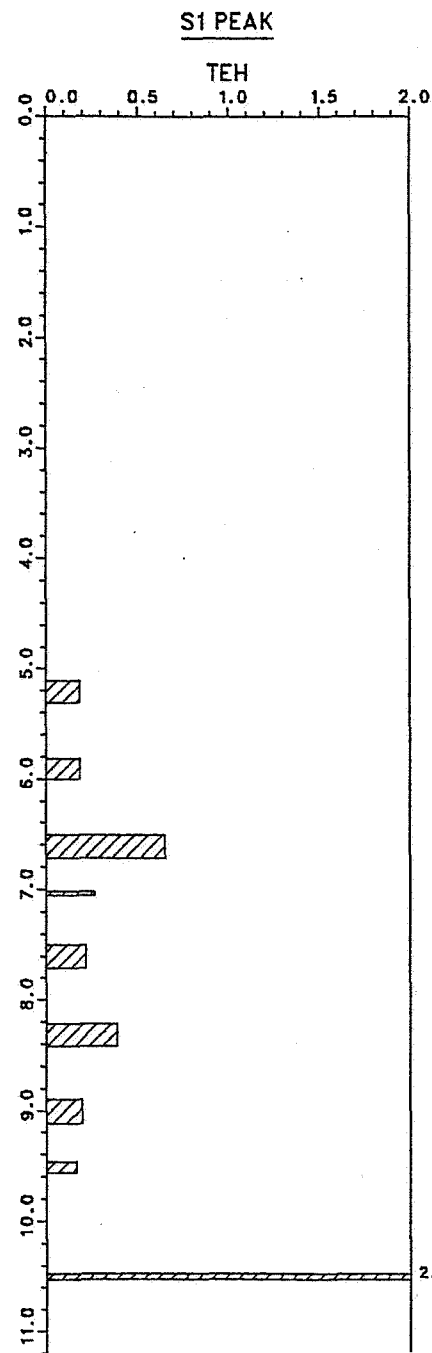
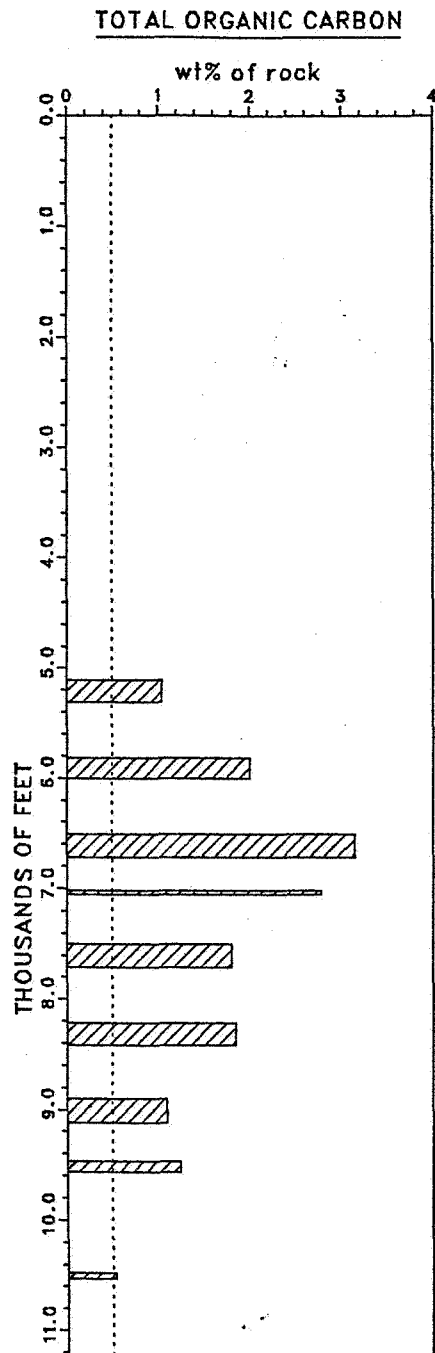

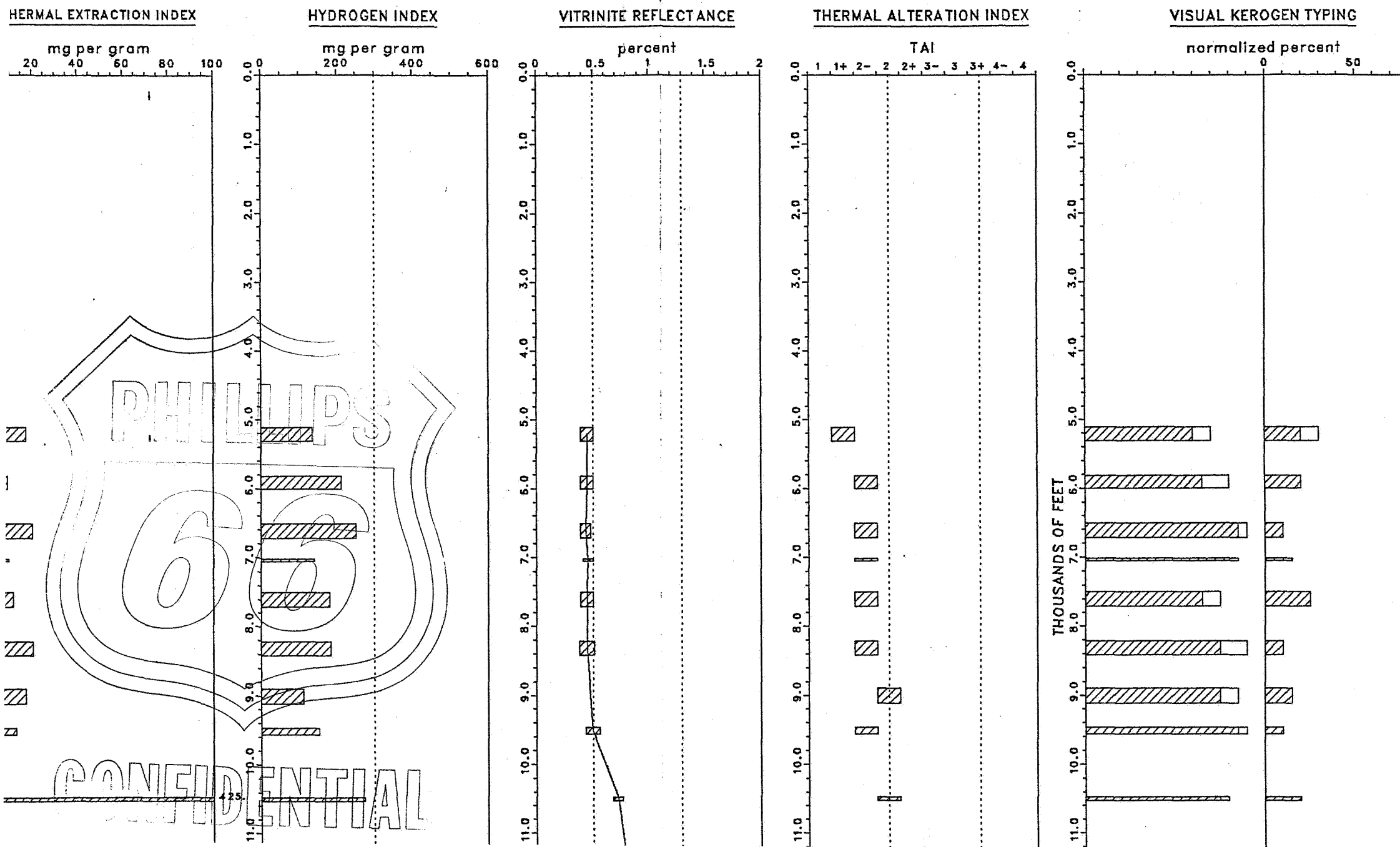

— CORE
 // CUTTINGS

TOR 2/5-1, NORWEGIAN SECTOR, NORTH SEA (ISOLATED KEROGEN)

PYROLYSIS RESULTS

BIOSTRAT
COMPOSITE

PLIOCENE

MIO-OLIG

EO-PALEO

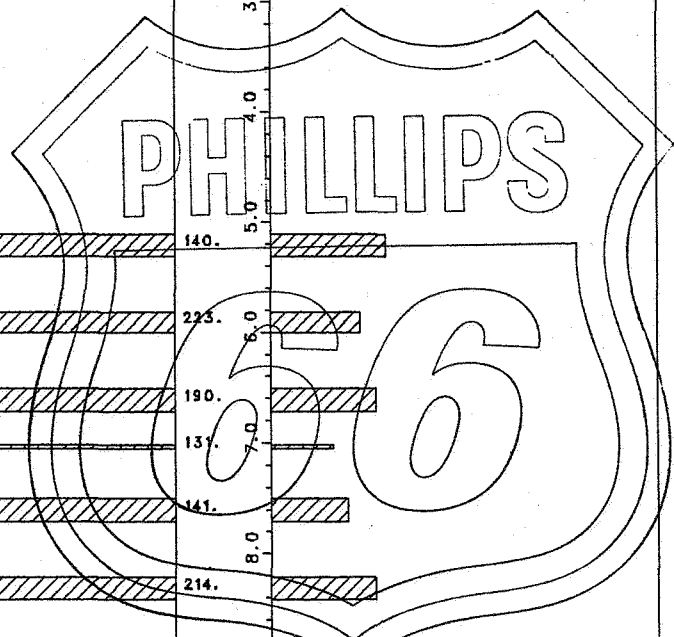
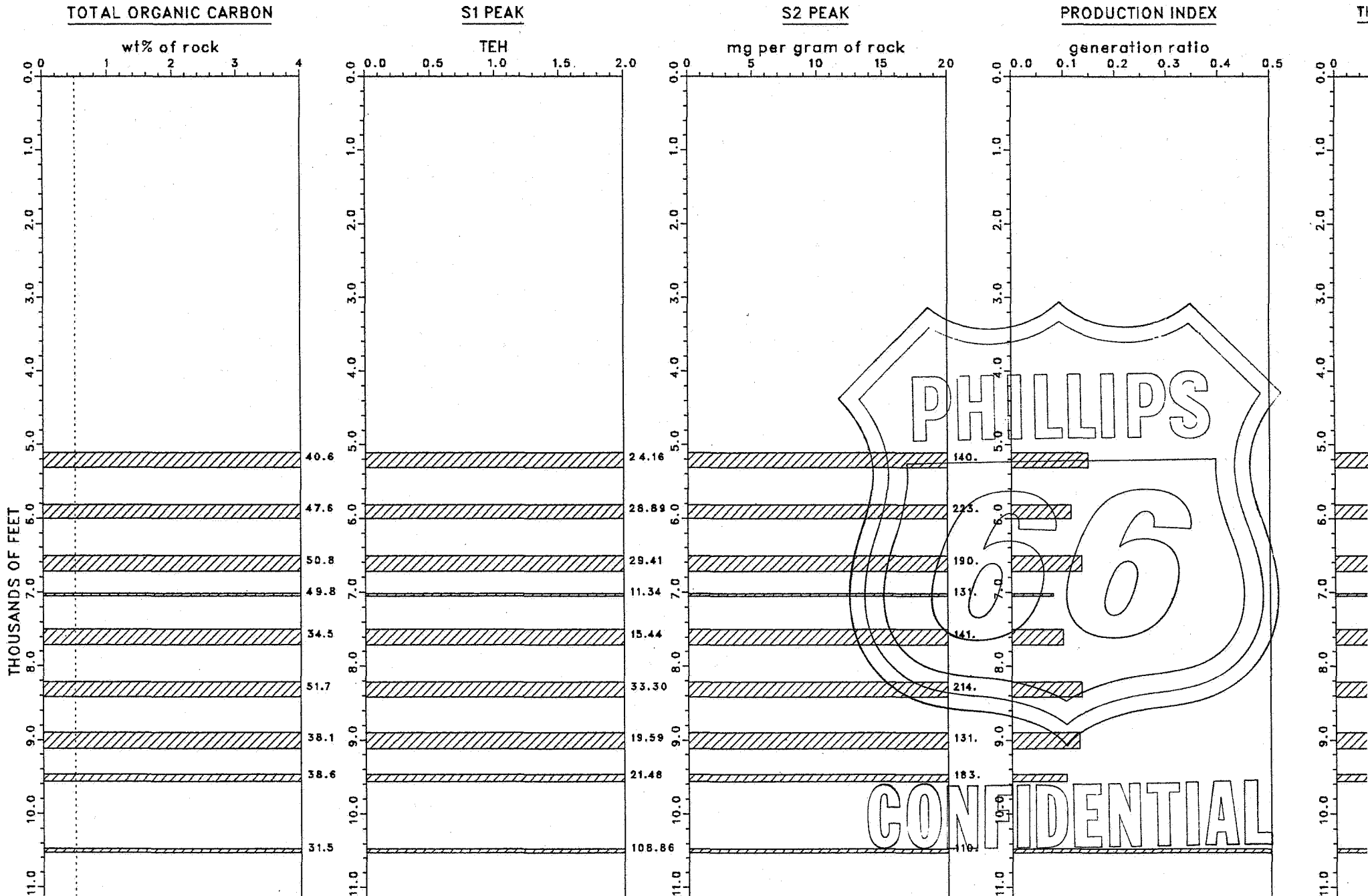

CONFIDENTIAL

TOR 2/5-1, NORWEGIAN SECTOR, NORTH SEA (ISOLATED KEROGEN)

PYROLYSIS RESULTS

HYDROGEN INDEX AND

H/C ATOMIC RATIO

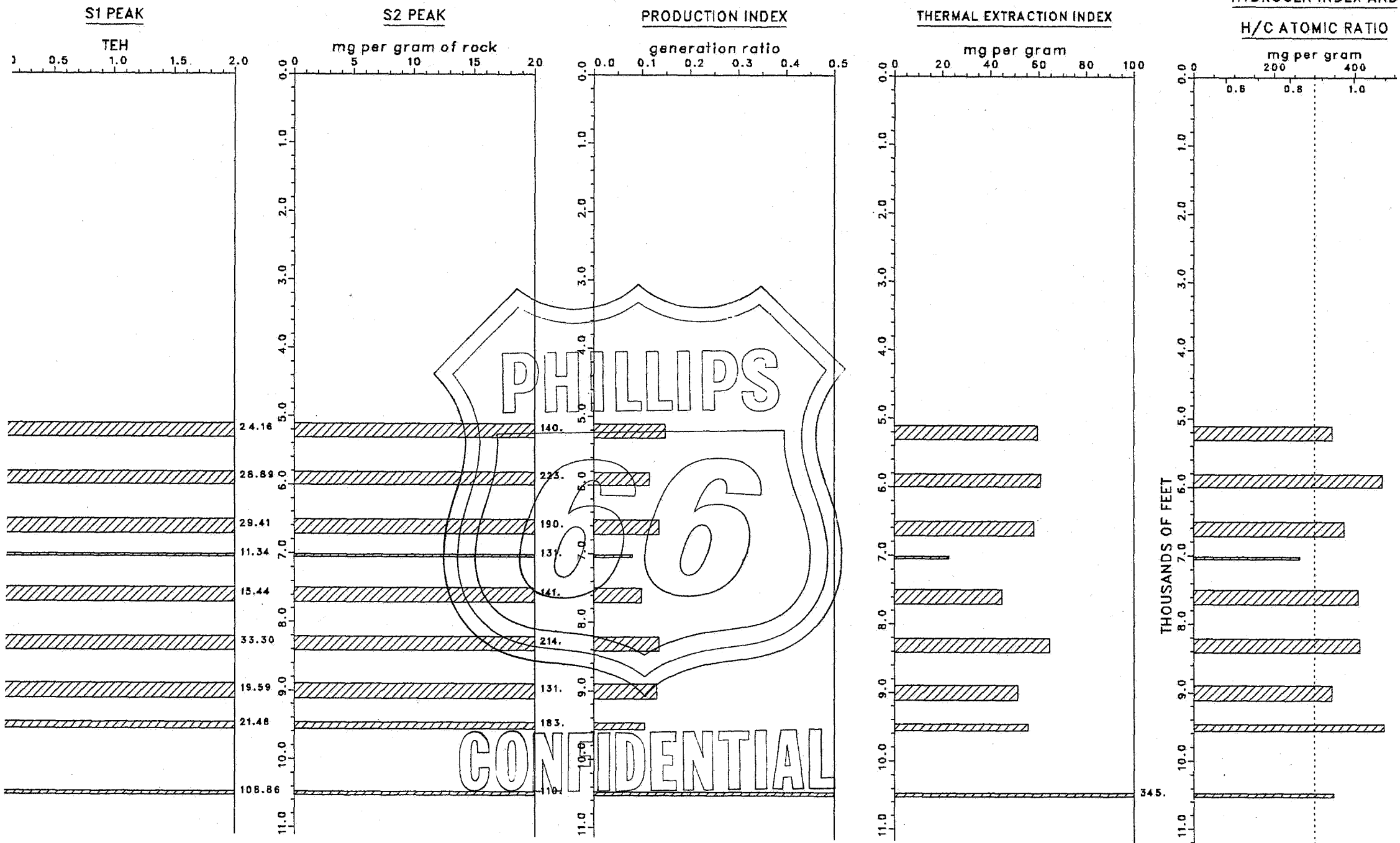

— CORE
 ▨ CUTTINGS

BIOSTRAT COMPOSITE
 PLIOCENE
 MIOCENE
 OLIGOCENE
 EO-PALEO

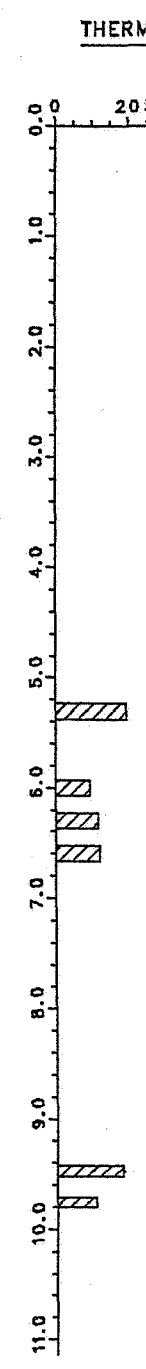
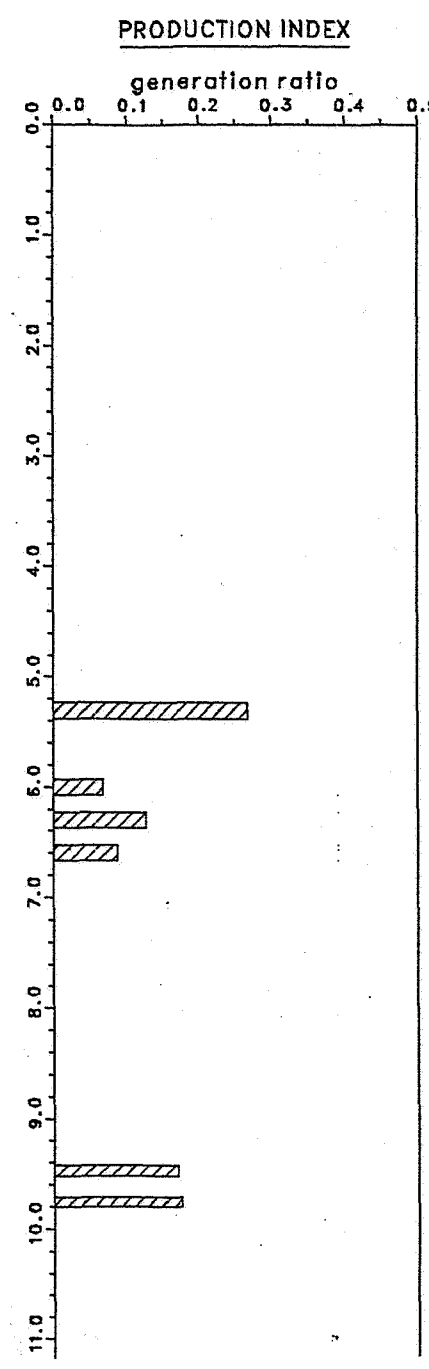
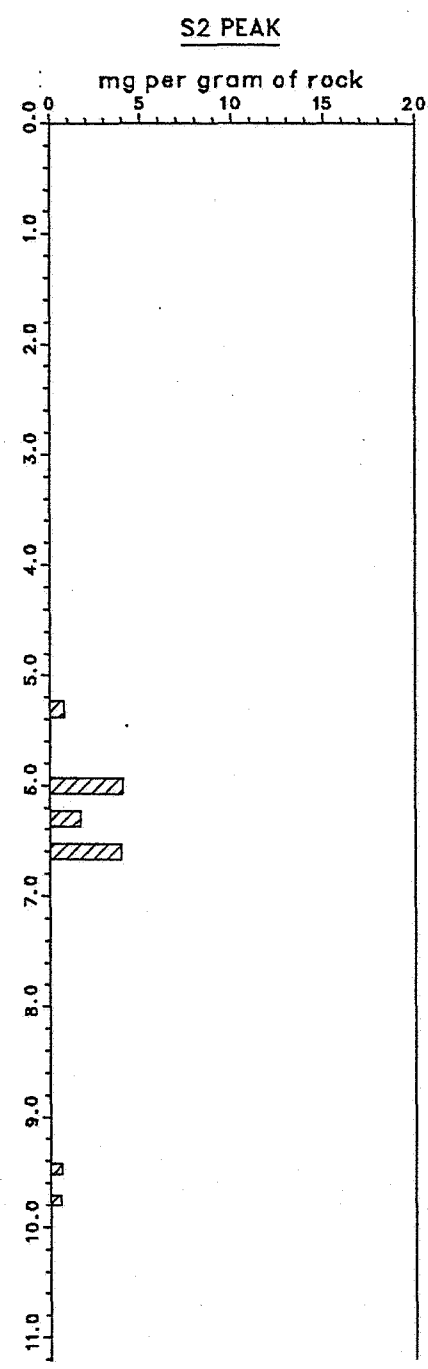
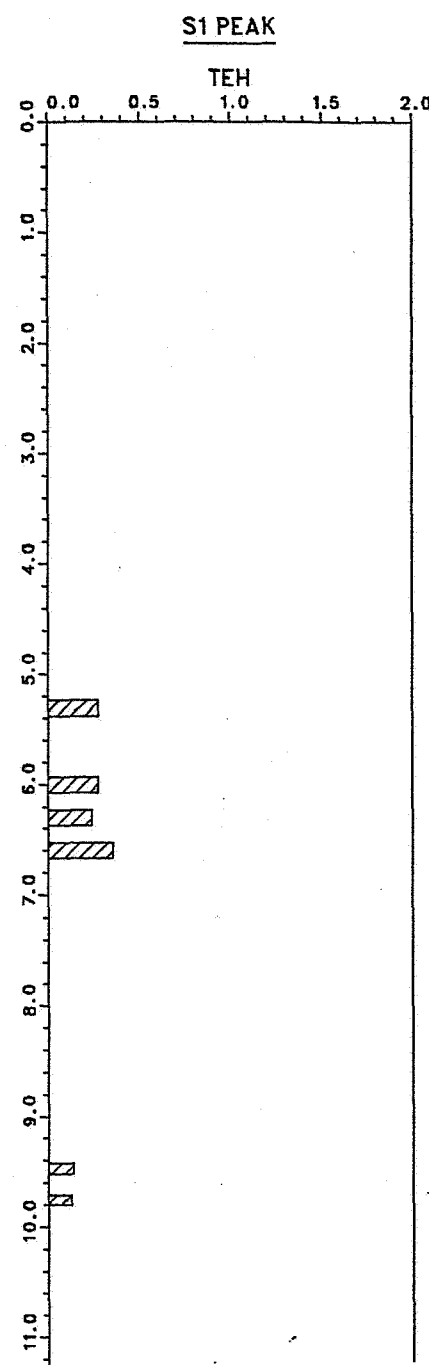
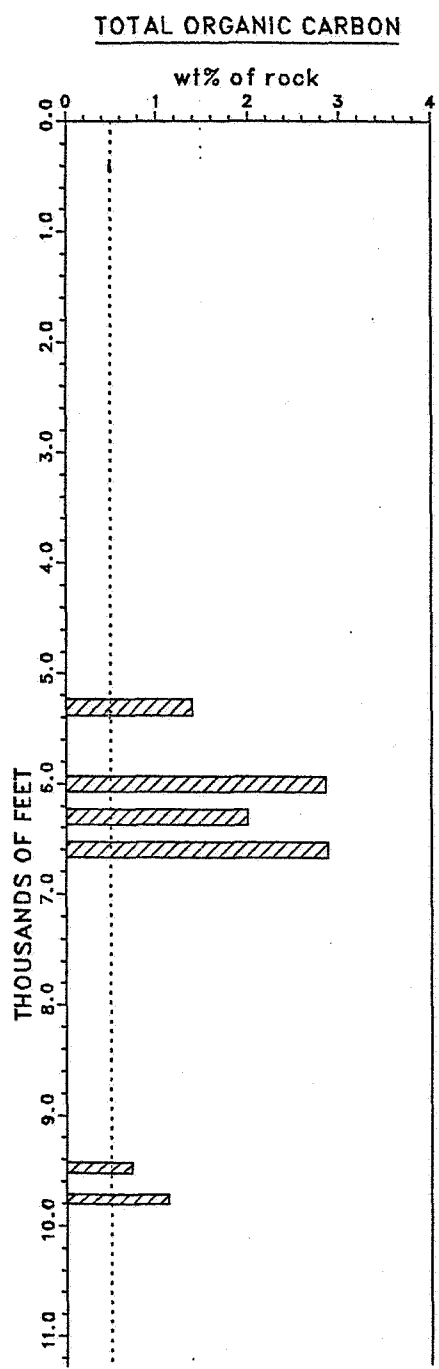

THERMAL EXTRACTION INDEX

HYDROGEN INDEX

VITRINITE REFLECTANCE

THERMAL ALTERATION INDEX

VISUAL KEROGEN TYPING

mg per gram
20 40 60 80 100

mg per gram
200 400 600

percent
0.5 1 1.5 2

TAI
1 1+ 2- 2 2+ 3- 3 3+ 4- 4

normalized percent
0 50

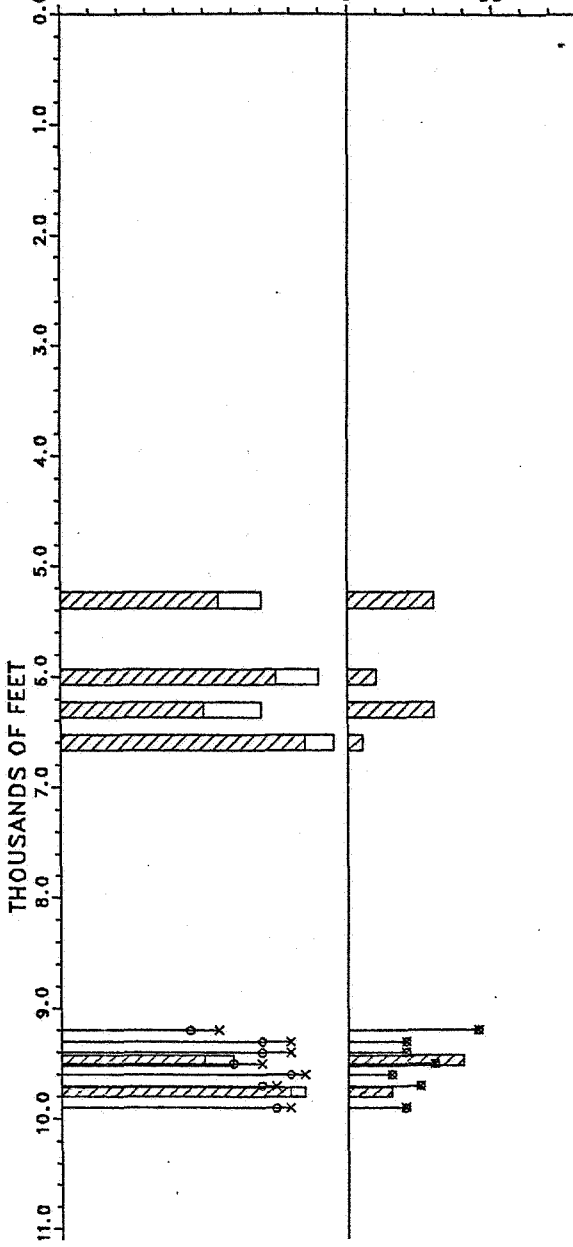
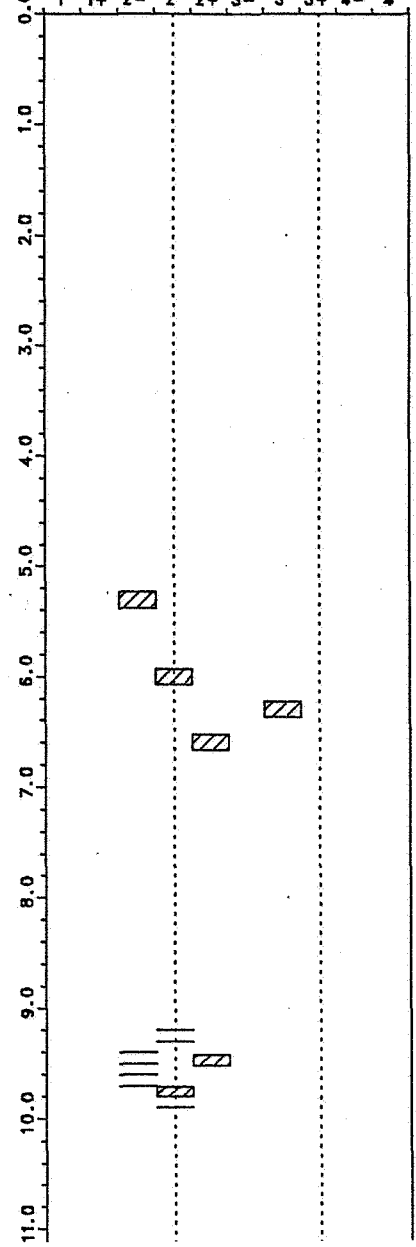
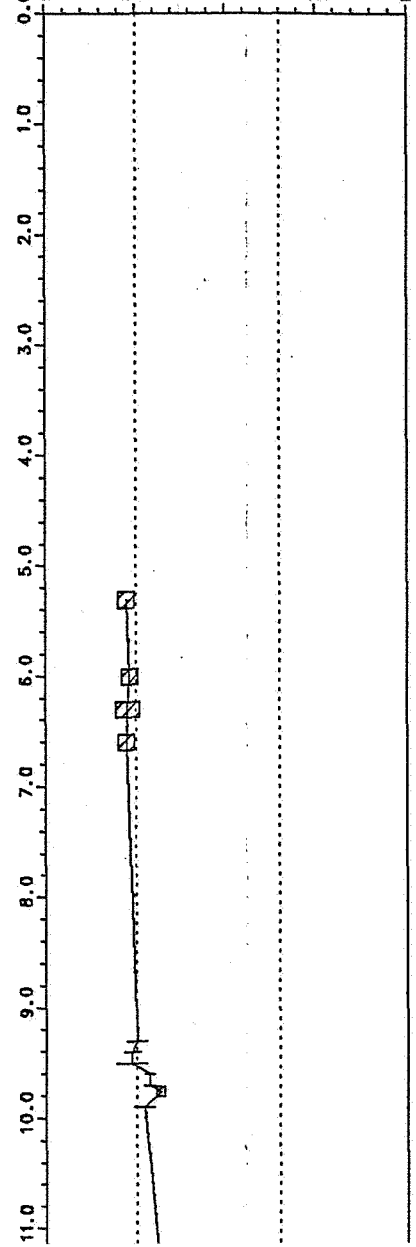
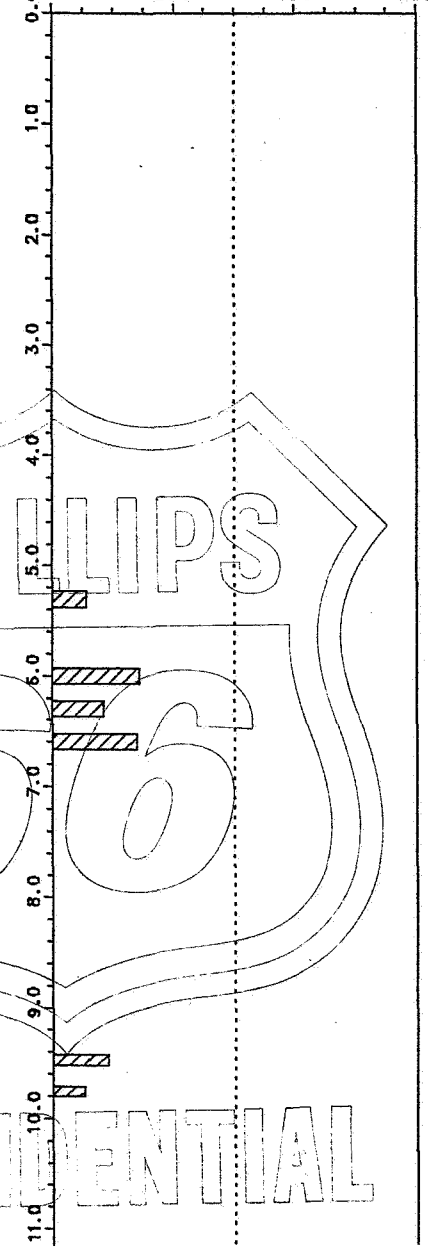
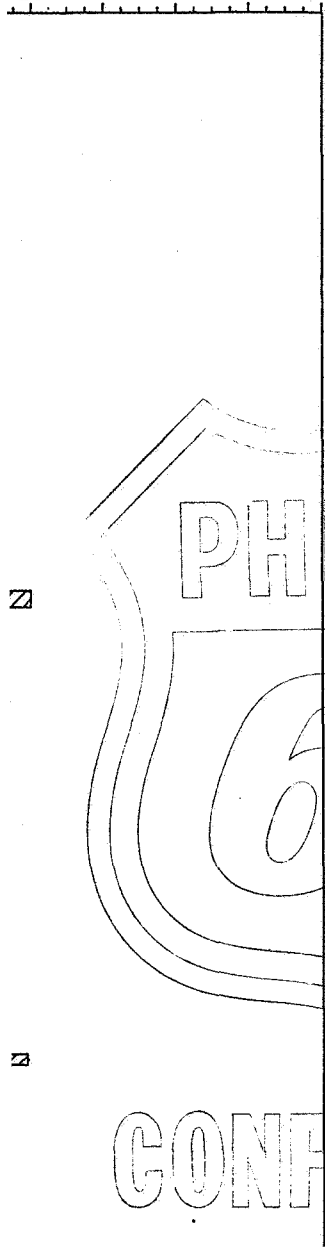

CONFIDENTIAL

ESPEN 2/4-11, NORWEGIAN SECTOR, NORTH SEA (ISOLATED KEROC

PYROLYSIS RESULTS

— CORE
 // CUTTINGS

BIOSTRAT
 COMPOSITE

PLIOCENE

MIOCENE

OLIGOCEN

EO-PALEO

TOTAL ORGANIC CARBON

wt% of rock

S1 PEAK

TEH

S2 PEAK

mg per gram of rock

PRODUCTION INDEX

generation ratio

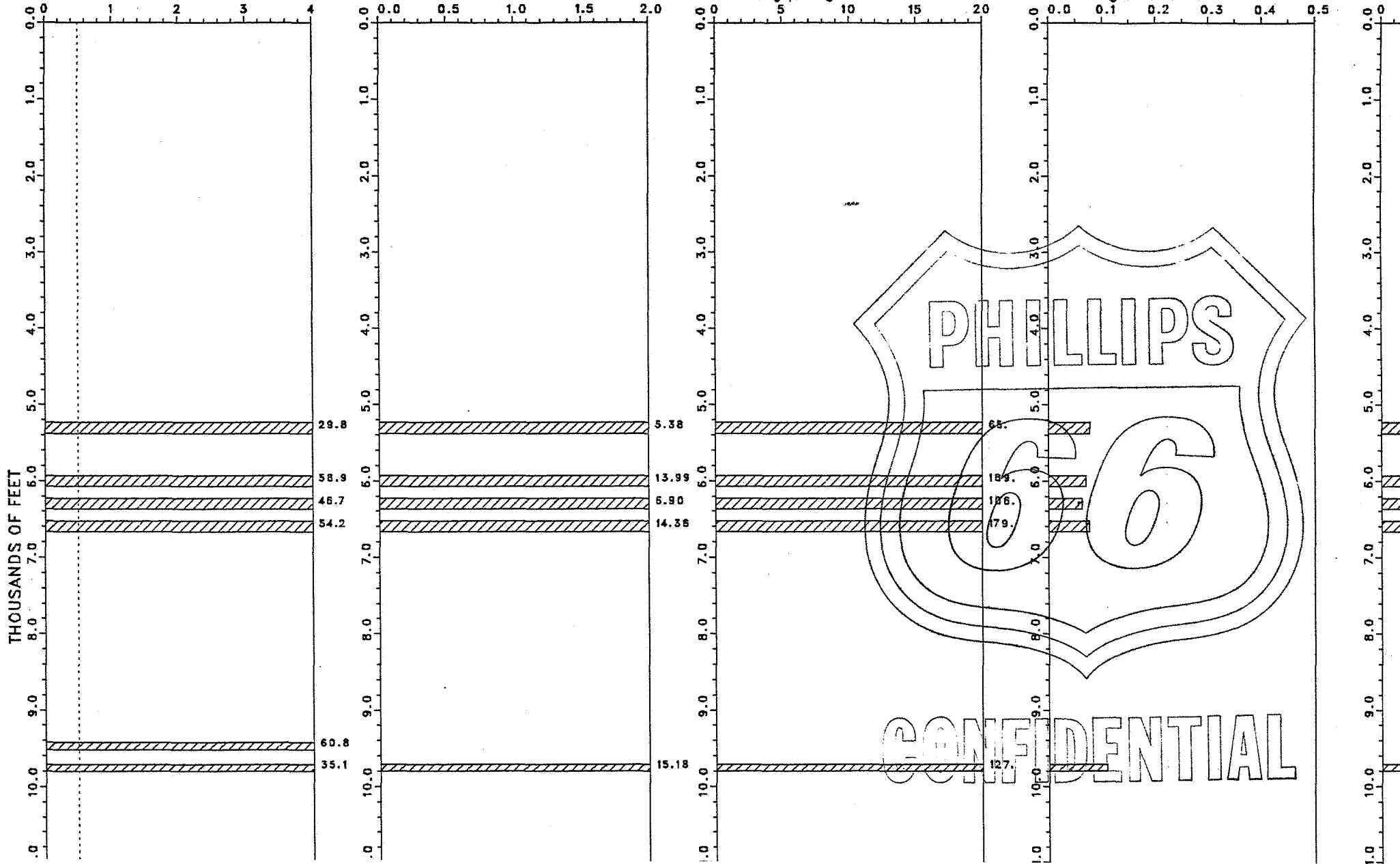

CONFIDENTIAL

PYROLYSIS RESULTS

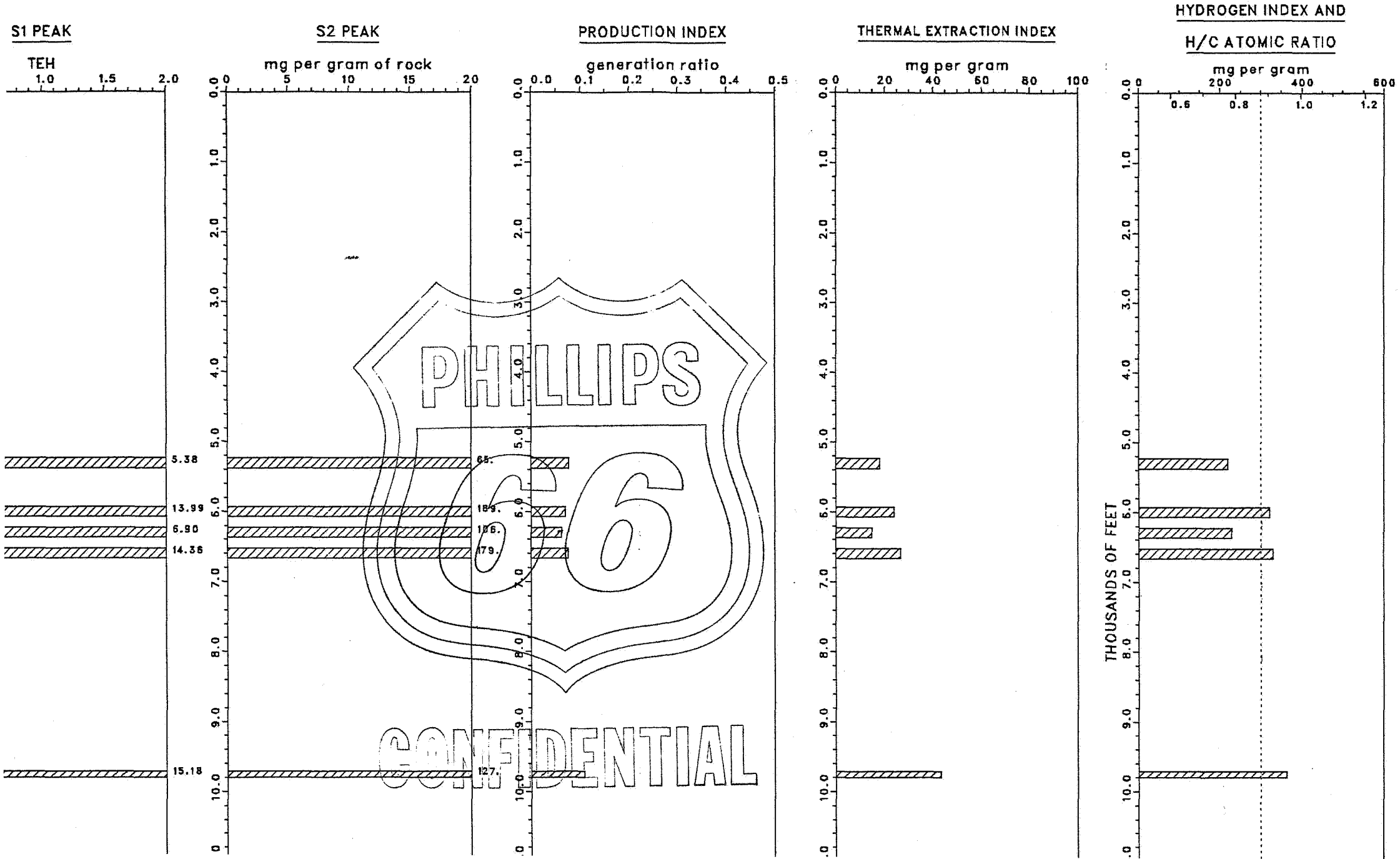

SOURCE ROCK REPORT/PLOT TERMINOLOGY

TOC/PYROLYSIS GEOCHEMICAL DATA:

TERM	ABBREV.	DESCRIPTION
TOTAL ORGANIC CARBON	TOC	THE AMOUNT OF ORGANIC CARBON IN A ROCK SAMPLE, EXPRESSED AS WEIGHT PERCENT OF THE ROCK SAMPLE
THERMALLY EXTRACTABLE HYDROCARBONS	S1 (TEH)	THE AMOUNT OF THERMALLY EXTRACTABLE HYDROCARBONS (HC) CURRENTLY IN THE ROCK SAMPLE, EXPRESSED AS MG.HC/G.ROCK
	S2	THE AMOUNT OF THERMALLY EXTRACTABLE HYDROCARBONS GENERATED FROM THE THERMAL BREAK DOWN OF THE KEROGEN IN THE SAMPLE (MG.HC/G.ROCK)
PRODUCTION INDEX	PI	$S1 / (S1 + S2)$
THERMAL EXTRACTION INDEX	TEI	$(S1 \times 100.0) / TOC$
HYDROGEN INDEX	HI	$(S2 \times 100.0) / TOC$

VISUAL KEROGEN DATA:

TERM	ABBREV.	DESCRIPTION
THERMAL ALTERATION INDEX	TAI	SPORE COLOR: 1-2 YELLOW 3-4 DARK BROWN 2-3 BROWN 5 BLACK
ALGINITE	ALG	(ALGAL DEBRIS PLUS CYSTS AND BODIES) PLUS AMORPHOUS SAPROPEL
EXINITE	EXI	POLLEN AND SPORE EXINE, PLANT CUTICLES, RESINS, AND OTHER STRONGLY FLUORSCENT ORGANIC MATTER PLUS AMORPHOUS HERBACEOUS (IF RECOGNIZABLE AS FROM A TERRESTRIAL SOURCE, IF NOT IT IS RECORDED UNDER ALGINITE)
VITRINITE	VIT	WOODY TISSUE (ALTERED TO HUMIC COMPOUNDS) PLUS NONFLUORESCENT STRUCTURED TRANSLUCENT MATERIAL PLUS AMORPHOUS VITRINITE
INERTINITE	INER	COALY MATERIAL INCLUDING FUSINITE, SEMIFUSINITE, PSEUDOVITRINITE, MACRINITE, AND INERTODETRINITE

BIOSTRATIGRAPHIC COLUMN (COMPOSITE)

INTERVAL	DEPTH
PLIOCENE	341
MIO-OLIG	5586
EO-PALEO	8683
CRET	10195
VOLGIAN	13344

SRP Evaluation from Modified QEST Method

Table I
EPS Report No. 2659A

Depth	Present Evaluation				Original Evaluation (Ro = 0.5%)				Formation
	Whole Rock TOC	Visual Kerogen	HI		Kerogen Generation Product	HI Kerogen	Peak BAF	Kerogen Generation Product	
<u>2/4-B19 Well:</u>									
13,360-370	2.13	oil	76	213	gas/oil	240	28	oil/gas	
13,370-380	2.91	oil	302	465	oil	530	88	oil	
13,400-500	1.25	oil	97	249	oil/gas	285	19	oil/gas	
13,500-600	1.47	oil	101	213	gas/oil	250	19	oil/gas	
13,680-800	2.38	oil	161	189	gas/oil	240	29	oil/gas	
13,800-14,000	1.37	oil	92	180	gas	240	16	oil/gas	
14,000-14,300	1.68	oil	80	174	gas	230	19	gas/oil	
<u>2/5-1 Well:</u>									
12,660-750	1.59	oil	128	251	oil/gas	305	26	oil/gas	
12,750-840	2.34	oil	179	196	gas/oil	230	27	gas/oil	
12,840-930	1.63	oil	158	225	gas/oil	270	25	oil/gas	
12,930-13,030	3.16	oil	122	159	gas/oil	205	34	gas/oil	
<u>2/4-11 Well:</u>									
13,070-110	.87	-	92	246	oil/gas	300	14	oil/gas	Mandal
13,100-200	.63	oil/gas	105	255	oil/gas	300	10	oil/gas	Farsund
13,310-500	1.82	oil	93	159	gas/oil	200	20	gas/oil	Farsund
13,600-800	.77	oil	82	164	gas	205	9	gas/oil	?Eldfisk?

Note: See Appendix A before using BAF data.

TABLE II

SOURCE ROCK GEOCHEMICAL AND VISUAL KEROGEN DATA

EKOFISK 2/4-B19, NORWEGIAN SECTOR, NORTH SEA (WHOLE ROCK)

STRAT INTERVAL	SPL TYP	SAMPLE DEPTH FEET	TOTAL ORGANC CARBON TOC	S1 PEAK (TEH)	S2 PEAK	THERMAL PRODUCTION		HYDRO GEN INDEX HI	VITRINTE REFLECTANCE (RO)		THERMAL ALTERATION INDEX TAI	VISUAL KEROGEN NORMALIZED PERCENT				GEOCHEM SAMPLE CODE				
						INDEX PI	INDEX TEI		MEAN	STD. DEV.		RO MODE	RO RANGE LOW	RO RANGE HIGH	RO RANGE PTS		ALG	EXI	VIT	INER
PLIOCENE CUT		4660-4749	1.42	.47	2.71	.15	33	191	.48	.03		.45	.54	26	2	80	5	15	EP84CMP	
PLIOCENE CUT		5020-5110	1.26	.54	1.94	.22	43	154	.49	.04		.44	.55	15	2	80	5	15	EP84CMQ	
MIO-OLIG CUT		5830-5920	2.93	1.72	11.13	.13	59	380	.47	.04		.42	.54	21	2	90	3	7	EP84CMR	
MIO-OLIG CUT		7000-7090	3.53	1.67	10.99	.13	47	311	.48	.03		.44	.54	46	2+	90	3	7	EP84CMS	
MIO-OLIG CUT		8018-8143	1.40	.47	3.20	.13	34	229	.51	.04		.44	.56	19	2	90	3	7	EP84CMT	
EO-PALEO CUT		8923-9009	1.13	.47	2.31	.17	42	204	.49	.03		.45	.59	32	2+	75	3	22	EP84CMU	
EO-PALEO CUT		9630-9720	.70	.20	.54	.27	29	77	.59	.06		.49	.67	12	2+	40	15	45	EP84CMV	
CRET CUT		11010-11100							.53	.07		.50	.63	10	2	50	20	30	EP84CBV	
CRET CUT		11410-11500							.47	.07		.42	.38	58	2	60	10	30	EP84CBW	
CRET CUT		11810-11900							.52	.09		.43	.40	67	2	60	10	30	EP84CBX	
CRET CUT		12410-12500							.57	.06		.54	.45	68	2	75	5	20	EP84CBY	
CRET CUT		13010-13100							.57	.10		.49	.48	69	2+	40	15	40	5	EP84CBZ
CRET CUT		13210-13300							.56	.04		.49	.51	62	2+	45	15	40		EP84CCA
CRET CUT		13340-13350	.91	.20	1.15	.15	22	126							2+	80	5	15		EP84CBM
VOLGIAN CUT		13360-13370	2.13	.28	1.62	.15	13	76	.66	.08		.53	.80	33	3-	70	2	28		EP84CBN
VOLGIAN CUT		13370-13380	2.91	.61	8.78	.06	21	302	.65	.08		.54	.77	8	3-	70	3	27		EP84BEO
VOLGIAN CUT		13400-13500	1.25	.25	1.21	.17	20	97	.73	.05		.65	.81	28	3	90	3	7		EP84BEP
VOLGIAN CUT		13500-13600	1.47	.33	1.49	.18	22	101	.74	.05		.66	.83	26	3	90	3	7		EP84BEQ
VOLGIAN CUT		13610-13700							.62	.06		.66	.53	72	2+	35	5	60		EP84CCB
VOLGIAN CUT		13680-13800	2.38	.38	3.84	.09	16	161	.81	.09		.68	.97	52	3	80	3	17		EP84BER
VOLGIAN CUT		13800-14000	1.37	.33	1.26	.21	24	92	.88	.07		.71	.96	46	3	70	2	28		EP84BES
VOLGIAN CUT		14000-14300	1.68	.47	1.34	.26	28	80	.84	.08		.71	.98	51	3-	75	5	20		EP84BET
VOLGIAN CUT		14010-14100							.66	.10		.56	.53	83	3-	30	5	65		EP84CCC
VOLGIAN CUT		14210-14300							.73	.09		.61	.61	88	3-	30	5	65		EP84CCD
VOLGIAN CUT		14300-14600	2.36	.43	1.07	.29	18	45	.89	.09		.75	1.01	41	3+	75	5	20		EP84BEU
VOLGIAN CUT		14410-14500							.80	.08		.69	.69	93	3	45	5	45	5	EP84CCE
VOLGIAN CUT		14600-14900	2.75	.73	1.56	.32	27	57	.93	.08		.79	1.05	42	3	75	3	22		EP84BEV
VOLGIAN CUT		14610-14700							.79	.08		.74	.68	94	3	40	5	55		EP84CCF
VOLGIAN CUT		14810-14900							.81	.09		.72	.65	94	3	35	5	60		EP84CCG
VOLGIAN CUT		14900-15100	3.11	.82	1.34	.38	26	43	.98	.07		.87	1.10	34	3+	80	5	15		EP84BEW
VOLGIAN CUT		15010-15100							.84	.11		.69	.69	99	3	30	5	60	5	EP84CCH

PHILLIPS PETROLEUM COMPANY - CONFIDENTIAL

PYROLYSIS RESULTS FOR SAMPLES FROM THE EKOFISK 2/4-B19, NORWEGIAN SECTOR, N. SEA (ISOLATED KEROGEN)

STRAT. INTERVAL	SPL TYP	SAMPLE DEPTH FEET	TOTAL ORGANIC CARBON WT. %	S1 MG. HC/ G. ROCK	S2 MG. HC/ G. ROCK	PRODUCTION INDEX S1/(S1+S2)	THERMAL EXTRACTION INDEX MG/G.	HYDROGEN INDEX MG/G.	HYDROGEN TO CARBON ATOMIC RATIO	GEOCHEM SAMPLE CODE
PLIOCENE	KER	4660-4749	58.72	20.02	287.49	.065	34.09	489.6	1.117	EP84CSQ
PLIOCENE	KER	5020-5110	52.11	27.10	180.24	.131	52.01	345.9	.936	EP84CSR
MIO-OLIG	KER	5830-5920	59.89	96.63	309.17	.238	161.35	516.2	1.150	EP84CSS
MIO-OLIG	KER	7000-7090	64.58	60.94	260.71	.189	94.36	403.7	1.009	EP84CST
MIO-OLIG	KER	8018-8143	30.74	36.25	142.13	.203	117.92	462.4	1.083	EP84CSU
EO-PALEO	KER	8923-9009	48.49	60.67	233.11	.207	125.12	480.7	1.106	EP84CTX
EO-PALEO	KER	9630-9720	61.76	27.19	69.30	.282	44.03	112.2	.641	EP84CTY
VOLGIAN	KER	13360-13370	57.79	32.25	123.16	.208	55.81	213.1	.769	EP84CSH
VOLGIAN	KER	13370-13380	62.22	40.04	289.40	.122	64.35	465.1	1.086	EP84CSI
VOLGIAN	KER	13400-13500	58.24	52.84	145.16	.267	90.73	249.2	.814	EP84CSJ
VOLGIAN	KER	13500-13600	65.00	51.71	138.75	.272	79.55	213.5	.769	EP84CSK
VOLGIAN	KER	13680-13800	61.94	43.56	116.83	.272	70.33	188.6	.738	EP84CSL
VOLGIAN	KER	13800-14000	64.69	46.13	116.49	.284	71.31	180.1	.727	EP84CSM
VOLGIAN	KER	14000-14300	62.58	42.21	109.09	.279	67.45	174.3	.720	EP84CSN
VOLGIAN	KER	14300-14600	67.28	31.06	85.03	.268	46.17	126.4	.659	EP84CSO
VOLGIAN	KER	14600-14900	68.18	34.34	94.50	.267	50.37	138.6	.675	EP84CTE
VOLGIAN	KER	14900-15100	69.23	33.04	80.26	.292	47.72	115.9	.646	EP84CSP

BIOSTRATIGRAPHY
(COMPOSITE)

INTERVAL	DEPTH
PLIOCENE	341
MIO-OLIG	5586
EO-PALEO	8683
CRET	10195
VOLGIAN	13344

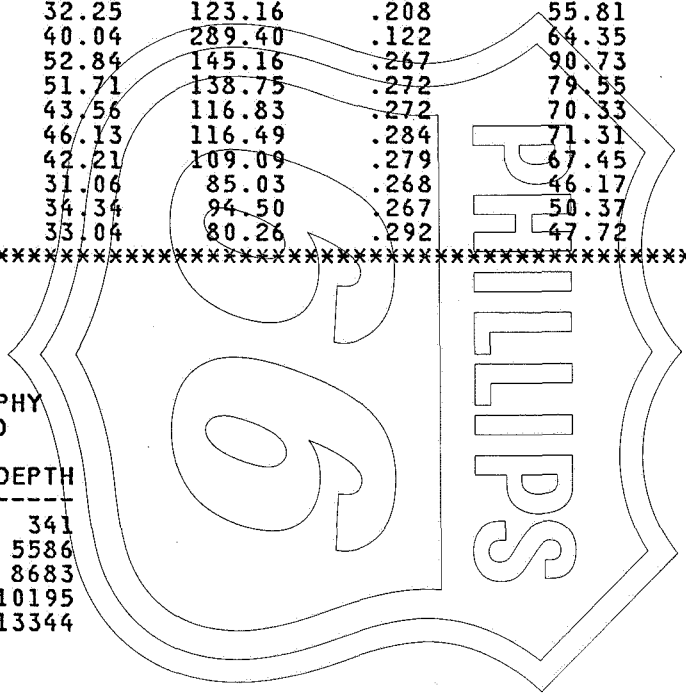

PHILLIPS PETROLEUM COMPANY - CONFIDENTIAL

TABLE V

SOURCE ROCK GEOCHEMICAL AND VISUAL KEROGEN DATA
TOR 2/5-1, NORWEGIAN SECTOR, NORTH SEA (WHOLE ROCK)

STRAT INTERVAL	SPL TYP	SAMPLE DEPTH FEET	TOTAL ORGANC CARBON TOC	S1 PEAK (TEH)	S2 PEAK	THERMAL PRODUC TION		HYDRO GEN INDEX HI	VITRINTE REFLECTANCE (RO)		RO RANGE LOW HIGH	PTS	THERMAL ALTERA- TION INDEX TAI	VISUAL KEROGEN NORMALIZED PERCENT				GEOCHEM SAMPLE CODE		
						INDEX PI	INDEX TEI		MEAN	STD. DEV.				OIL PRONE	GAS PRONE	VIT	INER			
PLIOCENE CUT		5110-5310	1.04	.18	1.41	.11	17	136	.44	.05	.39	.53	8	1+	60	10	20	10	EP84BSF	
MIO-OLIG CUT		5820-6000	1.99	.18	4.25	.04	9	214	.44	.05	.37	.53	20	2-	65	15	20		EP84BSG	
MIO-OLIG CUT		6510-6720	3.14	.64	7.91	.07	20	252	.43	.04	.41	.37	.53	74	2-	85	5	10		EP84BSH
MIO-OLIG CUT		7020-7050	2.77	.26	3.89	.06	9	140	.45	.04	.46	.38	.52	51	2-	80	5	15		EP84BSI
MIO-OLIG CUT		7500-7710	1.80	.21	3.27	.06	12	182	.44	.05	.38	.38	.55	25	2-	65	10	25		EP84BSJ
MIO-OLIG CUT		8220-8420	1.84	.38	3.41	.10	21	185	.44	.06	.40	.38	.55	18	2-	75	15	10		EP84BSK
		8900-9120	1.09	.19	1.22	.13	17	112						2	2	75	10	15		EP84BSL
EO-PALEO CUT		9470-9560	1.24	.16	1.90	.08	13	153	.49	.06	.40	.40	.59	18	2-	85	5	10		EP84BSM
L.CRET. CUT		10475-10525	.52	2.21	1.43	.61	425	275	.72	.04	.40	.69	.75	2	2	75	5	20		EP84BSN
L.CRET. CUT		11550-11750	.30	.25	.29	.46	83	97	.81	.15	.40	.66	.95	4	2+	75	5	20		EP84BSO
L.CRET. CUT		11740-11829	.68	2.76	.83	.77	406	122						2	2	85	3	12		EP84BSQ
L.CRET. CUT		12010-12099	2.24	6.88	3.05	.69	307	136	.88	.05	.79	.93	18	2+	85	5	10		EP84BSR	
L.CRET. CUT		12270-12359	1.28	5.34	1.48	.78	417	116	.82	.06	.75	.91	8	2+	85	2	13		EP84CSI	
L.CRET. CUT		12480-12569	1.54	5.37	2.07	.72	349	134	.85	.05	.79	.96	14	2+	80	3	17		EP84CSJ	
		12660-12749	1.59	4.72	2.04	.70	297	128	.81	.04	.75	.91	24	3-	80	5	15		EP84CSK	
VOLGIAN CUT		12750-12839	2.34	5.91	4.19	.59	253	179	.77	.04	.71	.85	25	3	82	3	15		EP84CSL	
VOLGIAN CUT		12840-12929	1.63	4.10	2.58	.61	252	158	.79	.05	.72	.88	23	3-	73	3	25		EP84CSM	
VOLGIAN CUT		12930-13030	3.16	6.35	3.87	.62	201	122	.84	.04	.77	.91	46	3-	75	2	23		EP84CSN	

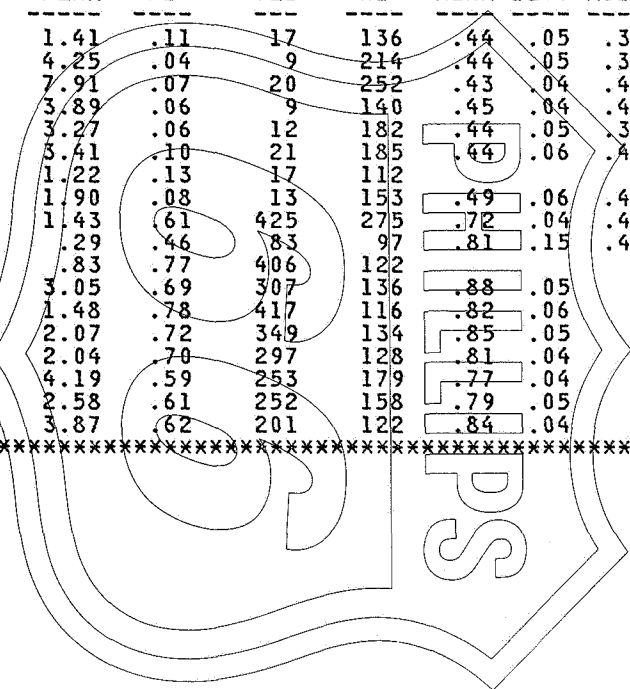

CONFIDENTIAL

PYROLYSIS RESULTS FOR SAMPLES FROM THE TOR 2/5-1, NORWEGIAN SECTOR, NORTH SEA (ISOLATED KEROGEN)

TABLE VI

PAGE 1 OF 1

STRAT. INTERVAL	SPL TYP	SAMPLE DEPTH FEET	TOTAL ORGANIC CARBON WT. %	S1 MG. HC/ G. ROCK	S2 MG. HC/ G. ROCK	PRODUCTION INDEX S1/(S1+S2)	THERMAL EXTRACTION INDEX MG/G.	HYDROGEN INDEX MG/G.	HYDROGEN TO CARBON ATOMIC RATIO	GEOCHEM SAMPLE CODE
PLIOCENE	KER	5110-5310	40.61	24.16	139.63	.148	59.49	343.8	.933	EP84BYN
MIO-OLIG	KER	5820-6000	47.58	28.89	223.32	.115	60.72	469.4	1.091	EP84BYO
MIO-OLIG	KER	6510-6720	50.79	29.41	189.50	.134	57.91	373.1	.970	EP84BYP
MIO-OLIG	KER	7020-7050	49.81	11.34	130.90	.080	22.77	262.8	.831	EP84BYQ
MIO-OLIG	KER	7500-7710	34.48	15.44	141.34	.098	44.78	409.9	1.016	EP84BYR
MIO-OLIG	KER	8220-8420	51.68	33.30	214.02	.135	64.43	414.1	1.022	EP84BYS
	KER	8900-9120	38.14	19.59	131.08	.130	51.36	343.7	.933	EP84BYT
E0-PALEO	KER	9470-9560	38.63	21.48	183.28	.105	55.60	474.4	1.098	EP84BYU
L.CRET.	KER	10475-10525	31.51	108.86	109.73	.498	345.48	348.2	.939	EP84BYV
L.CRET.	KER	11550-11750	42.18	52.61	73.02	.419	124.73	173.1	.718	EP84BYW
L.CRET.	KER	11740-11829	33.37	93.76	54.81	.631	280.97	164.2	.707	EP84CPQ
L.CRET.	KER	12010-12099	52.02	99.27	128.60	.436	190.83	247.2	.811	EP84CPR
L.CRET.	KER	12270-12359	32.98	113.73	68.95	.623	344.85	209.1	.763	EP84CPS
L.CRET.	KER	12480-12569	47.87	108.86	124.89	.466	227.41	260.9	.829	EP84CPT
	KER	12660-12749	53.60	144.66	134.41	.518	269.89	250.8	.816	EP84CPU
VOLGIAN	KER	12750-12839	56.76	131.93	111.08	.543	232.43	195.7	.747	EP84CPV
VOLGIAN	KER	12840-12929	53.49	89.02	120.55	.425	166.42	225.4	.784	EP84CPW
VOLGIAN	KER	12930-13030	51.55	92.86	82.12	.531	180.14	159.3	.701	EP84CPX

BIOSTRATIGRAPHY (COMPOSITE)

INTERVAL	DEPTH
PLIOCENE	313
MIO-OLIG	5600
E0-PALEO	8905
L.CRET.	10276
VOLGIAN	12680

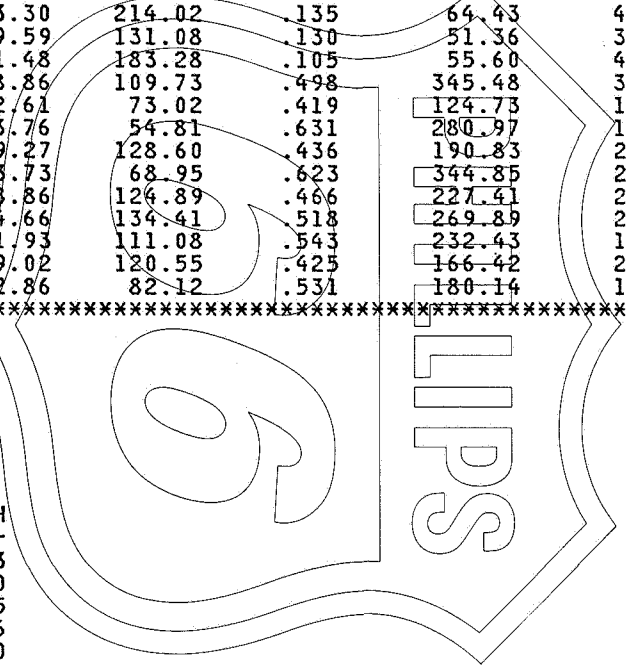

PHILLIPS PETROLEUM COMPANY - CONFIDENTIAL

SOURCE ROCK GEOCHEMICAL AND VISUAL KEROGEN DATA
 ESPEN 2/4-11, NORWEGIAN SECTOR, NORTH SEA (WHOLE ROCK)

EPS REPORT No. 2659A
 TABLE VIII

PAGE 1 OF 1

STRAT INTERVAL	SPL TYP	SAMPLE DEPTH FEET	TOTAL ORGANIC CARBON TOC	S1 PEAK (TEH)	S2 PEAK	THERMAL PRODUCTION		HYDROGEN INDEX HI	VITRINITE REFLECTANCE (RO)		THERMAL ALTERATION INDEX TAI	VISUAL KEROGEN NORMALIZED PERCENT				GEOCHEM SAMPLE CODE				
						INDEX PI	INDEX TEI		MEAN	STD. DEV.		RO MODE	RO RANGE LOW	RO RANGE HIGH	PTS		ALG	EXI	VIT	INER
PLIOCENE CUT		5230-5380	1.38	.27	.76	.26	20	55	.44	.04	.39	.39	.49	12	2-	55	15	30		EP84BYF
MIOCENE CUT		5930-6070	2.85	.27	4.04	.06	9	142	.46	.04	.40	.39	.53	65	2	75	15	10		EP84BYG
MIOCENE CUT		6230-6370	1.98	.23	1.66	.12	12	84	.45	.06	.47	.38	.54	7	3	50	20	30		EP84BYH
OLIGOCEN CUT		6530-6670	2.87	.35	3.93	.08	12	137	.44	.04	.45	.39	.52	55	2+	85	10	5		EP84BYI
OLIGOCEN SWC		9200													2	45	10	45		EP84BYJ
OLIGOCEN SWC		9300							.50	.05	.49	.41	.58	52	2	70	10	20		EP84BYK
OLIGOCEN SWC		9400							.47	.04	.49	.41	.52	13	2-	70	10	20		EP84BYL
OLIGOCEN CUT		9420-9520	.72	.13	.65	.17	18	90							2+	50	10	40		EP84BYM
OLIGOCEN SWC		9500							.47	.08	.33	.41	.52	2	2-	60	10	30		EP84BYN
OLIGOCEN SWC		9600							.57	.02	.33	.55	.58	2	2-	80	5	15		EP84BYO
EO-PALEO SWC		9700							.57	.03	.57	.52	.61	14	2-	70	5	25		EP84BYP
EO-PALEO CUT		9710-9800	1.12	.12	.58	.17	11	52	.63	.02	.64	.59	.65	22	2	80	5	15		EP84BYQ
EO-PALEO SWC		9900							.54	.05	.54	.45	.61	39	2	75	5	20		EP84BYR
L.CRET CUT		12000-12100	1.70	.53	1.78	.23	31	105							2+	30	20	30	20	EP84BYS
E.CRET SWC		12470							.69	.07	.74	.58	.77	9	2+	55	5	40		EP84BYT
E.CRET SWC		12618							.70	.07	.70	.58	.82	33	2+	70	10	20		EP84BYU
E.CRET SWC		12885													2+	45	18	36		EP84BYV
L.JUR SWC		13070-13110	.87	.14	.79	.15	16	91												EP84DIJ
L.JUR SWC		13075							.78	.06	.40	.72	.86	6	3-	65	5	30		EP84CBR
L.JUR CUT		13100-13200	.63	.15	.66	.19	24	105							3-	60	5	30	5	EP84BYX
L.JUR CUT		13310-13500	1.82	.17	1.70	.09	9	93	.80	.07		.71	.93	16	3	80	7	13		EP84CY
L.JUR SWC		13320							.79	.09	.80	.67	.93	30	3-	75	5	20		EP84CBY
L.JUR SWC		13510							.80	.06	.47	.73	.85	5	3-	80	5	15		EP84CBZ
L.JUR CUT		13600-13800	.77	.15	.63	.19	19	82	.80	.08		.69	.89	3	3	75	3	17	5	EP84CYN
L.JUR SWC		13712													3	60	10	30		EP84CBW

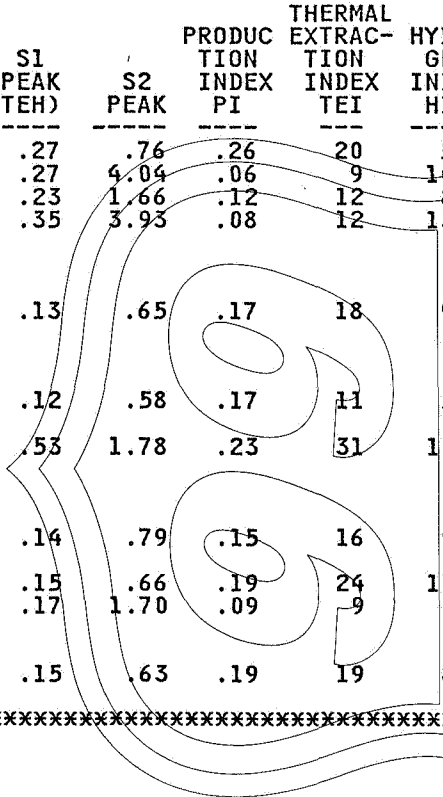

STRAT. INTERVAL	SPL TYP	SAMPLE DEPTH FEET	TOTAL ORGANIC CARBON WT. %	S1 MG. HC/ G. ROCK	S2 MG. HC/ G. ROCK	PRODUCTION INDEX S1/(S1+S2)	THERMAL EXTRACTION INDEX MG/G.	HYDROGEN INDEX MG/G.	HYDROGEN TO CARBON ATOMIC RATIO	GEOCHEM SAMPLE CODE
PLIOCENE	KER	5230-5380	29.84	5.38	65.24	.076	18.03	218.6	.775	EP84CAX
MIOCENE	KER	5930-6070	58.92	13.99	189.16	.069	23.74	321.0	.905	EP84CAY
MIOCENE	KER	6230-6370	46.67	6.90	106.17	.061	14.78	227.5	.787	EP84CAZ
OLIGOCEN	KER	6530-6670	54.21	14.36	179.04	.074	26.49	330.3	.916	EP84CBA
OLIGOCEN	KER	9420-9520	60.80							EP84CBB
EO-PALEO	KER	9710-9800	35.08	15.18	127.25	.107	43.27	362.7	.957	EP84CBC
L. CRET	KER	12000-12100	55.62	5.22	49.51	.095	9.39	89.0	.612	EP84CBD
	KER	13070-13110	50.59	38.63	124.54	.237	76.36	246.2	.810	EP84DJG
L. JUR	KER	13100-13200	16.10	9.11	41.01	.182	56.58	254.7	.821	EP84CBE
L. JUR	KER	13310-13500	46.38	26.56	73.86	.264	57.27	159.2	.701	EP84DAD
L. JUR	KER	13600-13800	54.76	33.64	89.99	.272	61.43	164.3	.707	EP84DAE

BIOSTRATIGRAPHY (COMPOSITE)

INTERVAL	DEPTH
PLIOCENE	334
MIOCENE	5785
OLIGOCEN	6471
EO-PALEO	9655
L. CRET	10696
E. CRET	12290
L. JUR	13073

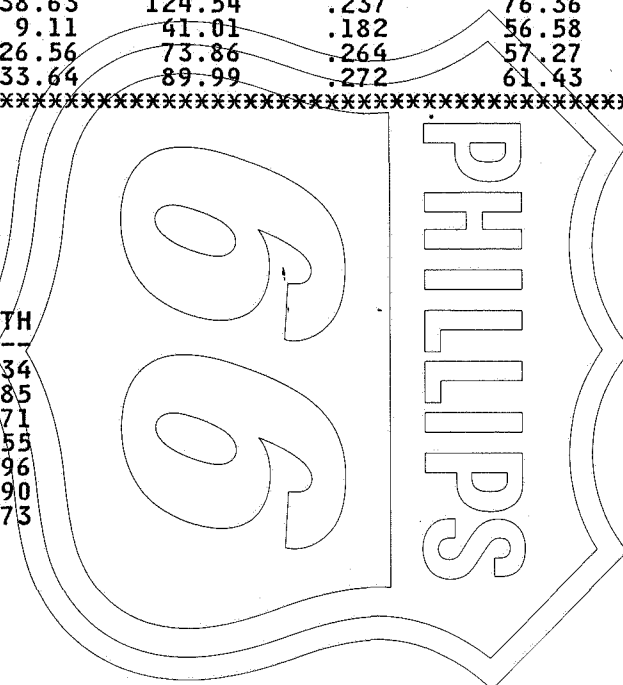

PHILLIPS PETROLEUM COMPANY — CONFIDENTIAL

